



Installation & Operation Manual

AIRRaider™ EZ⁹⁵
with Leader Pump



3 Saber Way
Ward Hill, MA 01835

Table of Contents

1. PRE-INSTALLATION	3
1.1. Safety Matters	3
1.2. Water Flow Requirements	4
1.3. Unpacking and Locating System Components	5
1.3.1. Unpack All System Components.....	5
1.3.2. Locate All Components.....	5
1.4. Use Qualified Technicians	5
1.5. Full Water Test	6
2. INSTALLATION INSTRUCTIONS	7
2.1. System Location	8
2.2. Preparing the System For Installation	8
2.3. Plumbing Hook-up	10
2.4. Electrical Hook-up	13
2.5. Vent Line Installation	14
2.6. Remote Air Intake	15
2.7. System Start-up	15
2.8. Balancing System	16
2.9. System Check	16
3. RETESTING	17
4. MAINTENANCE	17
4.1. Six Month Service (Recommended)	17
4.2. Annual Service (Required)	18
5. TROUBLE SHOOTING	19
6. ALARM SCHEMATIC	20
7. BLOWER BRUSH REPLACEMENT	21
8. EQUIPMENT SPECIFICATION	22
LIMITED WARRANTY	23

Table of Figures

Figure 1 – Pump Curve	4
Figure 2 – Typical System	7
Figure 3 – System Preparation	8
Figure 4 – Pump Installation	9
Figure 5 – Plumbing Arrangement	10
Figure 6 – Rear View, Unit Only.....	10
Figure 7 – Water Connections	11
Figure 8 – Electrical Schematic	12
Figure 9 – Vent Line Connection	14
Figure 10 – Vent Line Installation	14
Table 1 – AIRaider Output vs. Well Pump Output	16
Figure 11 – Blower Enclosure, Right side	21
Figure 12 – Blower Enclosure, Left side	21
Figure 13 – Blower Removal.....	21

1. Pre-Installation

The AIRRaider™ EZ⁹⁵ System is a diffused bubble aeration system for the removal of radon and other VOC's from residential water supplies. This installation and operation manual is designed to guide professionals through the safe and proper installation of the AIRRaider™ EZ⁹⁵ System.

Before beginning the installation of the AIRRaider™ EZ⁹⁵ System, there are 5 items to be considered. They are:

1. Safety
2. Installation site requirements
3. Inspection of System components
4. Qualified Technicians are necessary
5. Knowledge of all contaminants in the water

1.1. Safety Matters

Safety is the most important step in the installation process. Never perform any step of the installation that you are not qualified to perform (i.e. Electrical or plumbing hook up). It is important that you read through the entire manual prior to beginning the installation. When performing the installation, work slowly and deliberately. Follow all instructions carefully and never take shortcuts. Our team of technicians is available to answer your questions at 800-355-0901.



WORK SAFELY!

1.2. Water Flow Requirements

The AIRRaider™ EZ⁹⁵ System is designed for use with water flows up to 7 gallons per minute (GPM)* for optimum Radon Reduction. Higher outflow can be accommodated although higher flows will result in reduced water pressure (see Figure 1) and less radon reduction.

AIRRaider™ EZ⁹⁵ Pump Curve

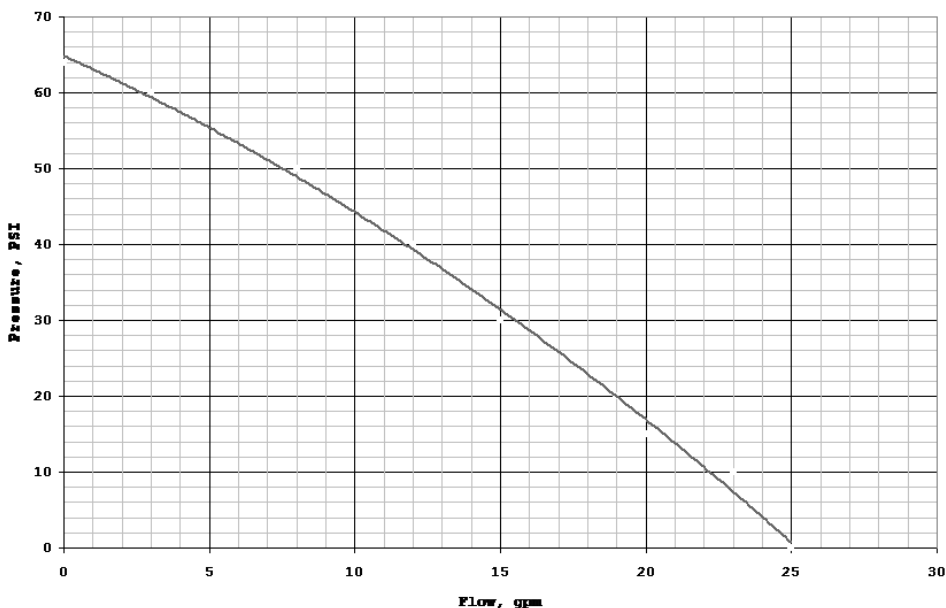

Figure 1. – Pump Curve

If a lower system outflow is needed, a flow control valve may be placed in the outlet piping and may be opened or closed by the amount necessary to balance the system. To avoid interruptions in the outflow from the AIRRaider™ EZ⁹⁵ System the well pump output must exceed the system outflow by at least 1 GPM at design flow (i.e. well output = 8 GPM; AIRRaider™ EZ⁹⁵ outflow setting = 7 GPM). If the well pump output is less than the system output the AIRRaider™ EZ⁹⁵ may run dry which will cause the pump, installed integrally within the AIRRaider™ EZ⁹⁵ System, to automatically shutdown. To prevent outflow interruptions it is strongly recommended that well pump water flow rate be determined before the AIRRaider™ EZ⁹⁵ System is installed.

**The AIRRaider™ EZ⁹⁵ System is not recommended for high flow residential properties. Other AIRRaider™ Systems are designed specifically for high flow residential properties. Separate repressurization systems are not required with the AIRRaider™ EZ⁹⁵ System but are available for other AIRRaider™ Systems. Proper repressurization system sizing is required to meet water flow needs. Consult manufacturer if assistance is needed for system selection.*

In order to determine available water flow rate the following is needed:

- Garden Hose
 - Five Gallon Bucket
 - Stop Watch or Watch with a Second Hand
- Or**
- Water Flow Meter

Household water use must be discontinued during the following flow rate test.

Mid-Range Flow Rate Test:

1. Attach garden hose to the drain connection on the base of the Well Pressure Tank.
2. Open the drain valve and run water for 15 minutes.
3. After 15 minutes, check the pressure gauge on the well system. Adjust the drain valve (open or close) as needed to maintain the required running system pressure (constant pressure on gauge) with the well pump running continuously.
4. Run for 5 minutes while ensuring that the pressure is not fluctuating.
5. Run water from the hose into a five gallon bucket. Using a stop watch, time how many seconds it takes to fill the bucket (Z sec.).
6. Determine the GPM by dividing 60 seconds by the number of seconds it took to fill the bucket (Z sec.). Multiply the answer by 5 gallons. This gives you the GPM.
$$\text{GPM} = (60 / Z) \times 5$$
7. Repeat steps 5 and 6 and average the 2 numbers. The answer is the well pump output in gallons per minute. It is recommended that this number be indelibly recorded in an obvious location, together with the date of test, as it will be required when setting the AIRaider™ EZ⁹⁵ System and may be required for future troubleshooting of the well pump system or the AIRaider™ EZ⁹⁵ System.

1.3. Unpacking and Locating System Components

1.3.1. Unpack All System Components

Remove all packing material and discard appropriately away from the work area.

1.3.2. Locate All Components

Check to ensure all components are intact and included in shipment.

Included Component List (may vary with order)

- Tank Assembly
- Pump (Inside Tank Assembly, not connected to discharge)
- Diffuser Assembly (In bubble wrap inside tank)
- Inlet Pipe Assembly (In bubble wrap inside box inside tank)
- Bypass Valve (Sold Separately)
- Manual

1.4. Use Qualified Technicians

A Licensed Plumber, Electrician, Contractor or Certified Water Treatment Specialist may be required to install the AIRaider™ EZ⁹⁵ System in accordance with the installation instructions. Check your Local and State Code and Licensing requirements.

Failure to follow the instructions may lead to poor system performance and/or possible system damage.

The Installation must comply with the National Electrical Code, NEC NFPA 70 and all applicable Local and State Codes! Electrical Wiring must be completed by a qualified and licensed electrician.

1.5. Full Water Test

A full Water Sample Analysis must be performed to determine the quality of the water that requires treatment. In many water supplies, contaminants other than Radon are present. The AIRaider™ EZ⁹⁵ System is only effective for the removal of Radon and some other VOC's. The Aeration Process employed by the AIRaider™ EZ⁹⁵ System and other Radon removal systems can worsen problems due to iron or manganese contaminants in the water supply. For optimal removal of Radon or other VOC's, other contaminants such as iron, or manganese must be removed before the water supply enters the AIRaider™ EZ⁹⁵.

**Failure to remove other contaminants can reduce the effectiveness of the system
and may result in system damage!**

2. Installation Instructions

OVERVIEW

Now you are ready to begin the installation process. The eight steps to properly install the AIRraider™ EZ⁹⁵ System are listed below. Read all components of each step prior to beginning the actual installation.

1. System Location
2. Readyng the System for Installation
3. Plumbing Hookup
4. Electrical Hookup
5. Vent Line Installation
6. Remote Air Intake Installation
7. System Startup
8. System Check



SAFETY TIP: Do Not undertake any step for which you are Not Qualified!



Figure 2 - AIRraider™ EZ⁹⁵ System

2.1. System Location

When selecting the location for the AIRRaider™ EZ⁹⁵ System, six factors should be among those considered:

1. System Plumbing Hookup. Find a location that will minimize the amount of plumbing necessary, this is typically in proximity to the well tank.
2. Electrical Hook-up. Keep in mind the need for accessibility to a 20 Amp dedicated 120VAC power supply.
3. Exhaust Line Venting. The location of the system must allow for outside venting of the system exhaust above the eave of the structure. The Manufacturer requires that the vent pipe pitch back toward the system (see Section 2.5.3).
4. Remote Air Intake. If the system must be installed in an area with questionable air quality (i.e. furnace room, garage, crawl space) then ducting from the air intake to a remote location having good air quality may be required.
5. System must be Level. The system should not be located on a significant slope as this may impede system performance.
6. Drain Location. The system is equipped with an overflow connection, it is recommended that this connection be directed to a drain or sump.

Place the system in the location acceptable to customer that maximizes the ease of installation. All Local and State codes as well as any applicable AARST, EPA and/or State Radon standards must be adhered to when locating the AIRRaider™ (i.e. away from electrical panel, furnace, exits, etc.).

2.2. Preparing the System for Installation

1. Remove Fasteners securing Cover to Tank and remove Cover Assembly (See Figure 3)
2. Remove all packing materials from inside the tank and between the mounting plate and pump controller (See Figure 4).
3. Insert the pex tubing from the pump control valve into the sharkbite elbow on the top of the pump/check valve assembly.
4. Connect the Union to attach the diffuser bar to the diffuser pipe. Make sure that the O Ring is present in the lower union half.

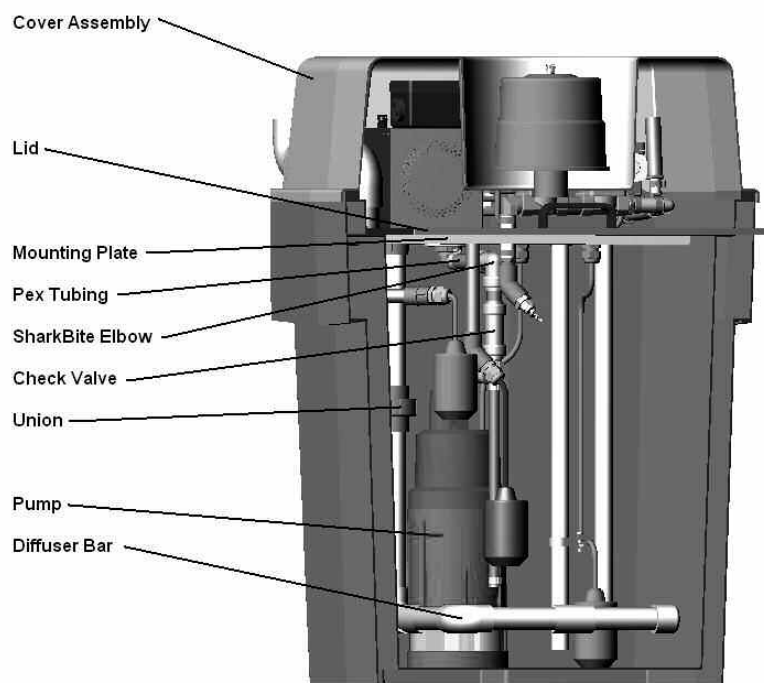

Figure 3 – System Preparation

5. Tighten the Liquid Tight Fitting Nut on Liquid Tight Fitting on the underside of the mounting plate.
6. Check that the Spray Nozzle is tight.
7. Check that the Liquid Tight Fitting Nuts on the Liquid Tight Fittings on the Float Cables are secure.
8. Mount the Lid and Lid Gasket. Do not secure with the Fasteners provided at this time.

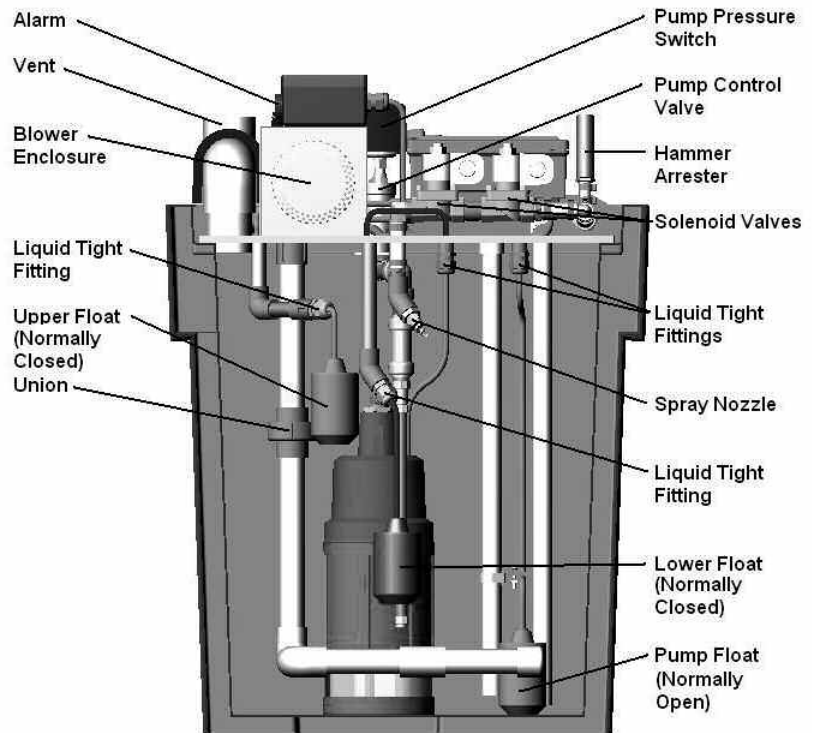

Figure 4 – Pump Installation

9. Tighten the Hose Clamps on the Rubber Couplings securing the Vent Pipe.
10. Replace the Cover Assembly. Do not secure with the Fasteners provided at this time.

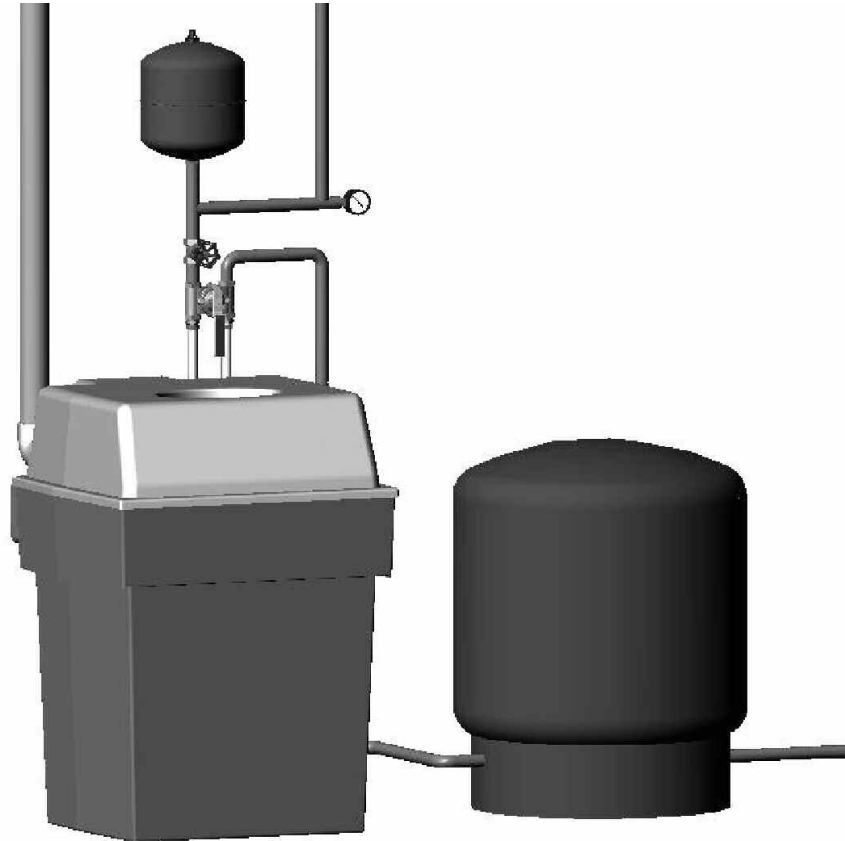

Figure 5 – Plumbing Arrangement

2.3. Plumbing Hookup

All Plumbing should be performed in accordance with Local and State Codes by a Qualified Plumber.

1. Shut off water main valve located after the pressure tank.
2. Drain water line.
3. Plumb system into water line after the pressure tank and all other water treatment equipment.
4. Plumb unit "Water In" connection (figure 6) to the inlet side of the bypass valve (figure 7).

For Ease of Servicing a 3/4" Sharkbite fitting is provided on the inlet. This is compatible with 3/4" pex or copper tubing

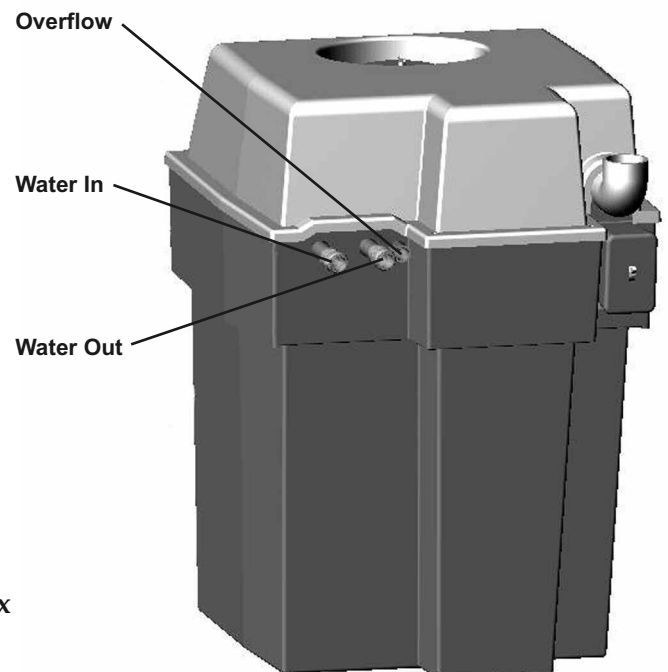

Figure 6- Rear View, Unit Only

5. Plumb unit "Water Out" connection (figure 6) to the outlet side of the bypass valve (figure 7).

For Ease of Servicing a 3/4" Sharkbite fitting is provided on the inlet. This is compatible with 3/4" pex or copper tubing. A Flow Control Valve located as shown is recommended. Location for Bladder /Pressure tank and optional pressure gauge is shown.

6. Plumb water line from the existing pressure tank into the bypass valve opening labeled "Water In" (figure 7).

Bypass Valve shown may be purchased separately from Spruce.

7. Plumb the water line to the house into the bypass valve opening labeled "Water Out" (figure 7). The built-in EZ Pump Pressure Switch with Smart Valve provided is designed for use with a pressure tank. The pressure tank bladder pressure should be set per the tank manufacturer's recommendations for a pressure switch setting of 40 psi.

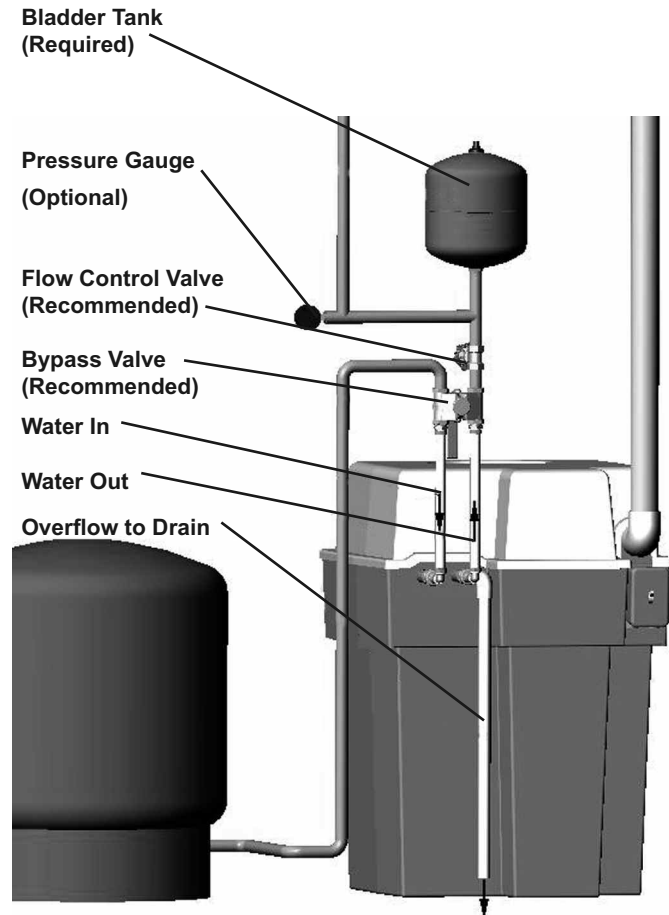

Figure 7 – Water Connections

8. With the bypass valve set to bypass configuration, handle at 90° to pipes if using the "Quadflo" Bypass Valve as illustrated, slowly open the main water valve and check for leaks.
9. Remove tank cover and slowly change bypass valve to service configuration and check for leaks.

2/18/09 TRS

AiRaider EZ⁹⁵ Schematic

- Wire Colors:**
 Black B
 White W
 Green G
 Red R
 Blue BL
 Brown BR
 □ Wire Nut

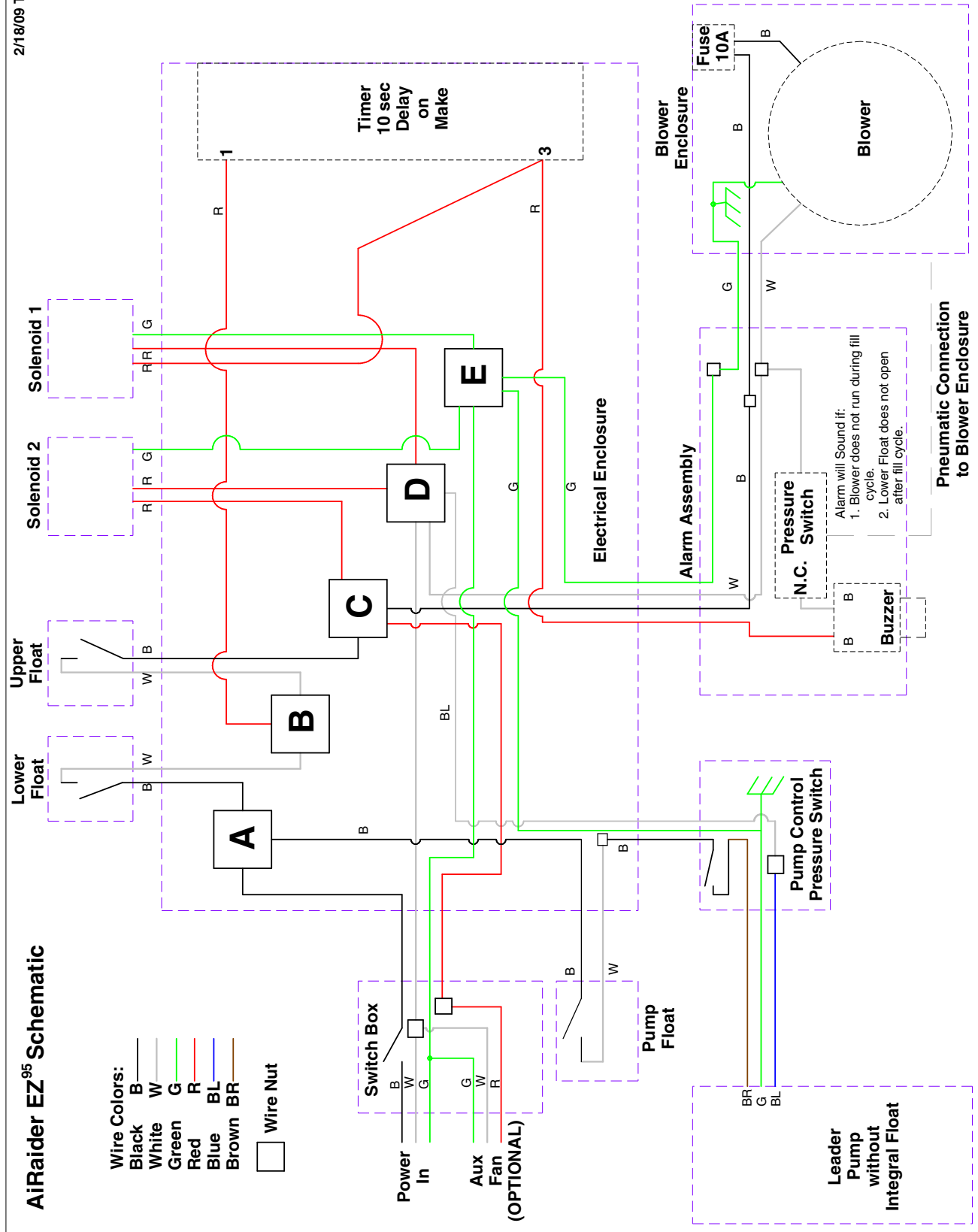

Figure 8 – Electrical Schematic

2.4. Electrical Hookup

The Installation must comply with the National Electrical Code, NEC NFPA 70 and all applicable Local and State Codes! Electrical Wiring must be completed by a qualified and licensed electrician.



WARNING: Never perform electrical work while standing in water. Do not attempt wiring on a live circuit.

WARNING: Power Supply Voltage must match the voltage marked on the System Name Plate. Improper wiring may result in system damage.

1. Turn main power switch, located on electrical box at rear left of unit, to the "Off" position.
2. Bring power into the electrical box via the hole provided.
3. Connect power line to the connections provided within the electrical box per the Electrical Schematic (figure 8). Ensure that the "red" lead, provided for an optional auxiliary fan, remains insulated if not used.
4. Connect power line to power source.* The AIRaider™ EZ⁹⁵ System requires a 115VAC 20Amp Supply, as marked on the system name plate located on the rear left hand corner of the tank. Follow all code requirements regarding wire and circuit breaker size.

* The manufacturer recommends that the AIRaider™ EZ⁹⁵ System be directly wired to the panel on a dedicated circuit.

2.5. Vent Line Installation

Use only 2", 3" or 4" Schedule 40 PVC or equivalent pipe for vent line. Follow all applicable AARST, EPA, and/or State Standards for Radon or VOC venting. Large diameter vent line pipe should be used in colder climates to prevent freezing.

1. Connect vent line to 2" socket elbow on the rear of the system (figure 9). Use PVC cement in a fashion that ensures no leakage will occur. Note: A rubber coupling permitting disconnection of the system from the vent line for future maintenance is provided beneath the cover.
2. The vent line must be mounted in a fashion that allows the system to exhaust 12 inches above the line of the roof (figure 10). [If the vent line is run internally, the exhaust point must be 12 inches above the roof penetration.]
3. The vent must be pitched back towards the system to ensure that any condensation runs back into the unit. If an optional auxiliary fan is used recommendations regarding pipe pitch in the fan installation instructions must be strictly adhered to.
4. If an optional auxiliary fan is used, the fan must be wired to the system electrical box, connecting as shown in the Electrical Schematic (figure 8). This will ensure that the fan operates only when required by the system.
5. Install weather cap on top of the vent line. This cap should not restrict air flow and must prevent rain, snow and other contaminants from entering the vent line.



Failure to install a proper vent line may cause contamination of the water, out gassing of contaminants into the building, and/or limit system performance.

* The manufacturer has found that vent lines less than 250 equivalent linear feet do not cause a decrease in contaminant removal percentages.

90° Bend = 15 Equiv. Linear Ft ; 45° Bend = 7 Equiv. Linear Ft.

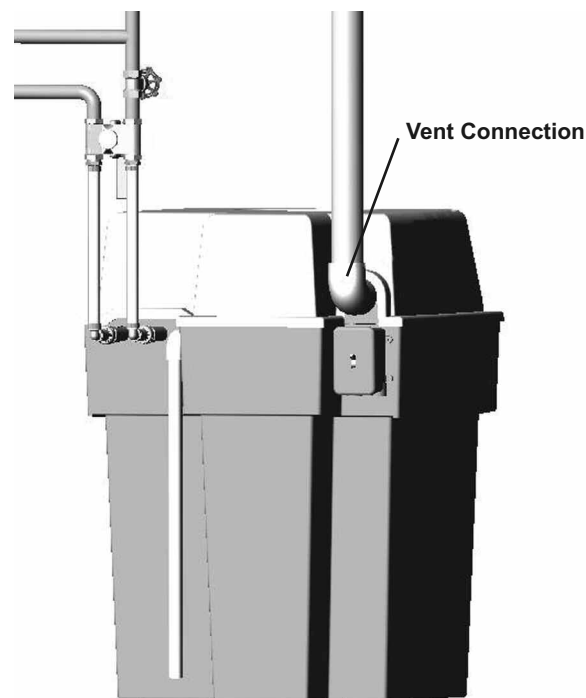

Figure 9 – Vent Line Connection



Figure 10 – Vent Line Installation

2.6. Remote Air Intake

If a Remote Air Intake is required because of Air Quality or Quantity issues, then Use Only 1-1/4" or larger Schedule 40 PVC or equivalent pipe for the air intake line.

1. Attach the optional blanking plate to the EZ⁹⁵ Cover with 1-1/4" pipe connection.
2. Run intake line from the pipe connection on the blanking plate to the location selected for air intake.

Note: A rubber coupling or similar means to disconnect the intake line from the AIRraider™ must be provided so that the AIRraider Cover may be removed for Start-up and Maintenance.

3. Connect a suitable undamped air intake with screen to the intake end of the intake line.

Note: A filter/silencer is mounted in the AIRraider™ EZ⁹⁵ System Cover. Additional inline filters are not required. If the air intake is located outside, the intake must be mounted high enough to prevent the drawing in of snow, water and other contaminants. Do not locate the air intake in the vicinity of vents from furnaces, barbecue grills, etc.

2.7. System Startup

1. Remove cover and lid and pour 1/4 cup of chlorine into the AIRraider Tank (This will disinfect the system). Secure the lid with the screws and washers provided, note that the 2 longer screws go in the center rear holes attaching lid to mounting plate.
2. Check that all plumbing and electrical connections have been properly completed.
3. Slowly change bypass to the "service" configuration. Check for leaks.
4. Turn power switch for AIRraider to "On". Solenoid Valves will now open allowing water into the system. The aeration process will also start. Check for leaks.
5. Allow the AIRraider™ to fill with water. The aeration process will stop. The pump will self prime during the filling cycle. The pump will start and water will discharge into the tank. The pump will continue running until the house water system is pressurized. Check thoroughly for leaks around all pipe joints etc. and seal if required.

2.8 Balancing System

If the pump does not continuously supply water under maximum outflow conditions, then the outflow from the AIRRaider™ EZ⁹⁵ probably exceeds the well pump output previously determined in section 1.2. This may be remedied by closing the flow control valve, at maximum demand, until continuous output is obtained. For optimum radon removal the outflow should be adjusted to the value given in table 1 for the measured well pump output. This is done by temporarily attaching a hose to the house connection of the bypass valve and adjusting the flow control valve to provide the correct fill time for the 5 gallon bucket used to determine flow rate (or the correct flow rate if using a flow gauge).

WELL PUMP OUTPUT,GPM	AIRRaider Output, GPM	Fill Time (5 Gal Bucket EZ95 Out) Secs.	WELL PUMP OUTPUT,GPM	AIRRaider Output, GPM	Fill Time (5 Gal Bucket EZ95 Out) Secs.
2	1.8	171	10	8.8	34
3	2.6	114	11	9.6	31
4	3.5	86	12	10.5	29
5	4.4	69	13	11.4	26
6	5.3	57	14	12.3	24
7	6.1	49	15	13.1	23
8	7.0	43	16	14	21
9	7.9	38			

Table 1 - AIRRaider Output vs. Well Pump Output

2.9 System Check

1. Run the system through a couple of cycles to ensure all components are working properly.
2. The blower operates for the duration of the fill cycle. When the fill cycle ends the blower should shut off.
3. If the blower fails to operate, the alarm buzzer will sound. The alarm buzzer will also sound if the lower float fails to operate. The function of the alarm buzzer can be checked by pinching the 1/8" diameter clear plastic tubing between the Tee's on the rear of the blower enclosure while the blower is running.
4. Replace the cover and secure with the fasteners provided. With the System running check the cover for air leaks between gasket and cover. If leaks occur the gasket may need to be repositioned and fasteners retightened.
5. Make sure you have properly labeled the system with the necessary installer information (i.e. Company name, phone number, date installed, etc.) and have left all system information with the home owner.
6. The AIRRaider™ EZ⁹⁵ System is now operational.

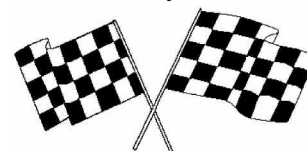

3. Retesting

After the AIRaider™ Installation, the installer should perform another water analysis to ensure proper system performance. This sample should be performed one week after the date of installation.

Sampling Procedure:

1. Remove aerator from faucet or spigot, if applicable.
2. Run water so that the AIRaider™ operates for two cycles.
3. Turn off water for 5 minutes.
4. Turn water on and proceed with sampling as per the laboratory instructions.

4. Maintenance

Proper maintenance of the AIRaider™ can prevent possible system failure and provide years of trouble free service.

4.1. Six-Month Service (Recommended)

The following procedures should be followed to maintain the AIRaider™:

- Check and/or clean the blower air intake filter.
- Check and/or clean any filters or strainer installed on the inlet line to the AIRaider™.
In installations with particularly high levels of sediment cleaning of filters may be required more frequently.
- Check and clean inlet screen on pump.
- Using a wet/dry vac, clean sediment from bottom of aeration tank if necessary.
- Clean (if necessary) tank and diffusers of all mineral build up.
- Chlorinate tank and lines by pouring ¼ cup of chlorine into the tank.
- Check all control panel connections and electrical components (blower, blower brushes, pump, alarm/buzzer, fuses, etc.) for proper operation.
- Check float switches for proper operation.
- Inspect vent line for possible obstructions.
- Run system through two cycles to ensure good working order.

4.2. Annual Service (Required)

The following procedures should be followed annually to maintain the AIRaider™:

- Clean solenoids and switch coil locations.
- Check any hose connections.
- Check and/or clean the blower air intake filter.
- Check and/or clean any filters or strainer installed on the inlet line to the AIRaider™.
- Check and clean inlet screen on pump.
- Using a wet/dry vac, clean sediment from bottom of aeration tank if necessary.
- Clean (if necessary) tank and diffusers of all mineral build up.
- Chlorinate tank and lines by pouring ¼ cup of chlorine into the tank.
- Check all control panel connections and electrical components (blower, blower brushes, pump, alarm/buzzer, fuses, etc.) for proper operation.
- Check float switches for proper operation.
- Inspect vent line for possible obstructions.
- Run system through two cycles to ensure good working order.
- Perform Water Test.

NOTE: Every 3 years during the annual service replace any Hoses and Blower Brushes.

Every 5 years during the annual service replace the Solenoid Valves and Blower Brushes.

5. Trouble Shooting

Symptom	Solution
<u>No water in house</u>	<ul style="list-style-type: none"> • Check power: Switch in ON position; circuit breaker at panel in ON position. • Bypass System. If there is still no water, main well pump may not be functioning. • Check float switches including pump float for proper operation. Replace if necessary.
<u>System running dry</u>	<ul style="list-style-type: none"> • Check sediment strainer and/or filter (if applicable) and clean if necessary. • Install a flow restrictor or meter down the ball valve until the AIRRaider™ outflow is approx.1 GPM less than the water flow entering the system.
<u>Water not entering system</u>	<ul style="list-style-type: none"> • Check solenoids for proper operation. Replace if necessary. • Check float switches for proper operation. Replace if necessary. • Check sediment strainer and/or filter (if applicable) and clean if necessary.
<u>Pump not functioning</u>	<ul style="list-style-type: none"> • Check power: Switch in ON position; circuit breaker at panel in ON position. • Check pump float switch for proper operation. • Open 1/4" valve above pump to break possible airlock. • Replace pump if necessary.
<u>Low water flow at faucets</u>	<ul style="list-style-type: none"> • Clear sediment strainers on faucets. • Clear pump inlet screen. • Replace pump if necessary.
<u>Loud banging when solenoids shut</u>	<ul style="list-style-type: none"> • Install additional water hammer suppressor or loop of flexible hose in pump inlet line. • Shorten the length of pipe between the well pressure tank and the system.
<u>Solenoids chatter when closing</u>	<ul style="list-style-type: none"> • Check On/Off float for proper operation. Replace if necessary.
<u>Blower does not stop running</u>	<ul style="list-style-type: none"> • Check On/Off float for proper operation, raising the blue lower float manually should shut off the blower.
<u>Pump is short cycling</u>	<ul style="list-style-type: none"> • Check Bladder Tank if installed • Add Bladder tank to house water line.
<u>Blower does not run</u>	<ul style="list-style-type: none"> • Check Blower Fuse. • Check Blower Brushes

AIRaider EZ⁹⁵ Alarm Schematic.

Wire Colors:

WHITE W ———
 GREEN G ———
 RED R ———
 BLACK B ———

WIRE NUT 

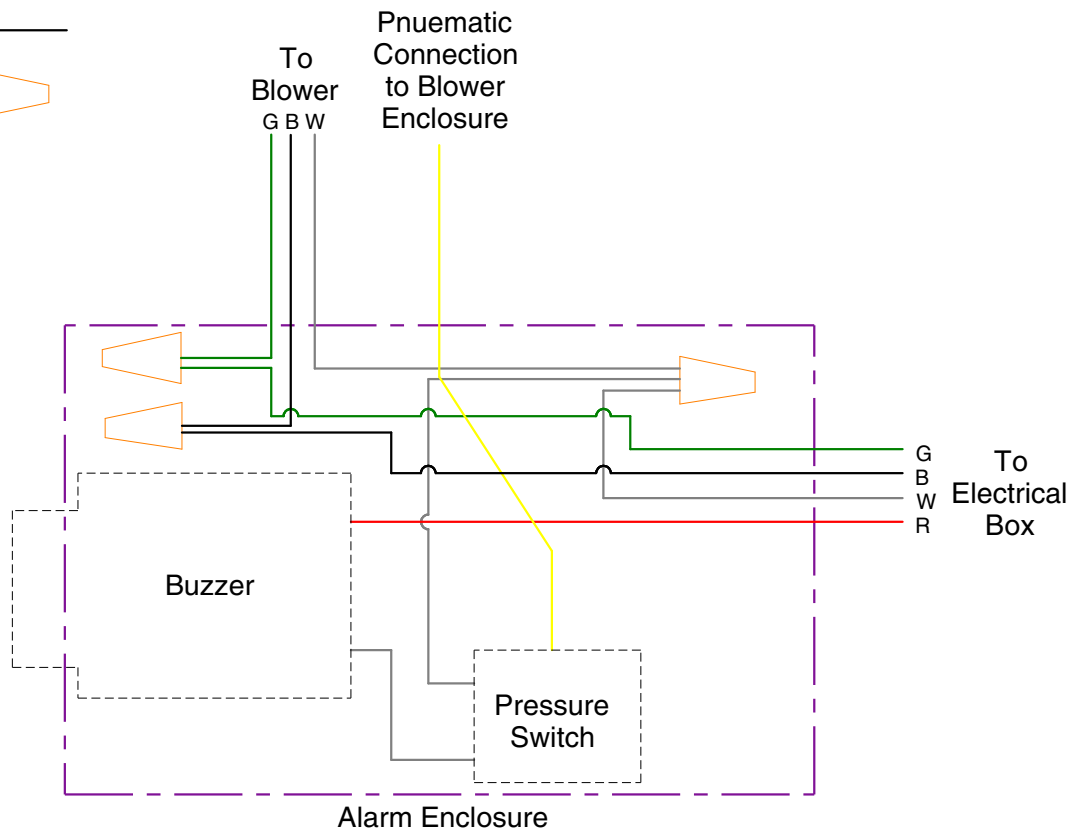

The Alarm is intended to Sound if no Pressure is applied to the pressure switch while the Alarm Circuit is Energized.

When mounted on the AIRaider Unit as intended the Alarm will Sound during the Fill Cycle if:

1. The Blower does not run (i.e. Blower does not pressurize Blower Enclosure)
2. The Pneumatic Connection to the Blower Enclosure is broken, blocked or disconnected.
3. The Pressure switch has failed

The Alarm will Sound after after the Fill Cycle has completed if:

1. The lower float fails (i.e. does not open).

A momentary Alarm will sound at the start of the fill cycle if the Delay on Make Timer (located in the AIRaider Electrical Enclosure) fails to function or is omitted (Red Wire is directly connected to Wire Nut "B" in AIRaider Electrical Enclosure). The sole purpose of the Delay on Make Timer is to prevent momentary Sounding of the Alarm at the start of the fill cycle as the Alarm circuit is energized momentarily before the Blower pressurizes the Blower Enclosure.

7. Blower Brush Replacement

1. Remove the 6 Hex Slotted Head Screws and the 4 Phillips Pan Head Screws as shown in figure 11 and 12.

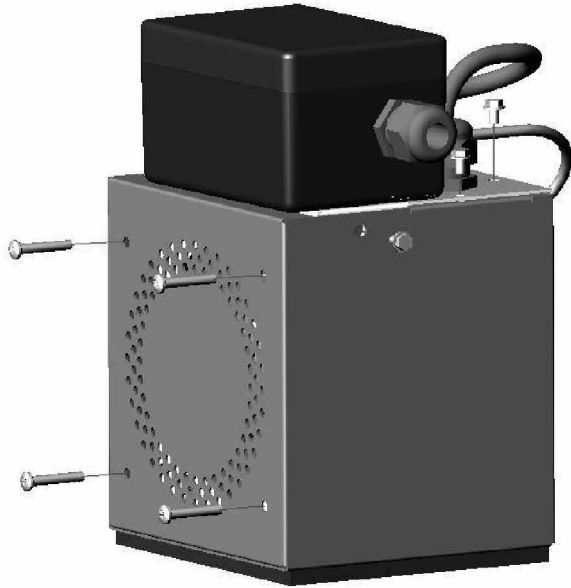

Figure 11 - Blower Enclosure, Right Side

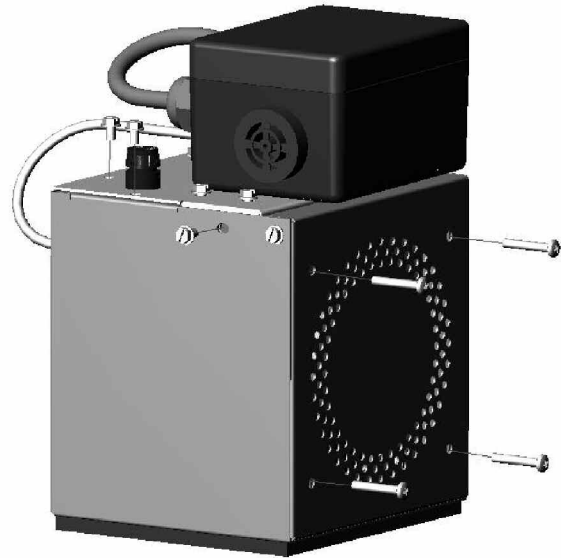

Figure 12 - Blower Enclosure, Left Side

2. Remove plastic tube from barb fitting and lift alarm assembly, enclosure cover and blower from the blower enclosure box (see fig 13).
3. The screws retaining the brush housings to the blower are now accessible without further disassembly.
4. Remove the screw retaining one of the brush holder assemblies.
5. Remove the brush holder assembly from the motor.
6. Insert the new brush holder assembly, making certain that brass prongs engage the electrical socket, and then replace the retaining screw.
7. Repeat steps 4-6 for the other brush holder. Always replace both brushes.

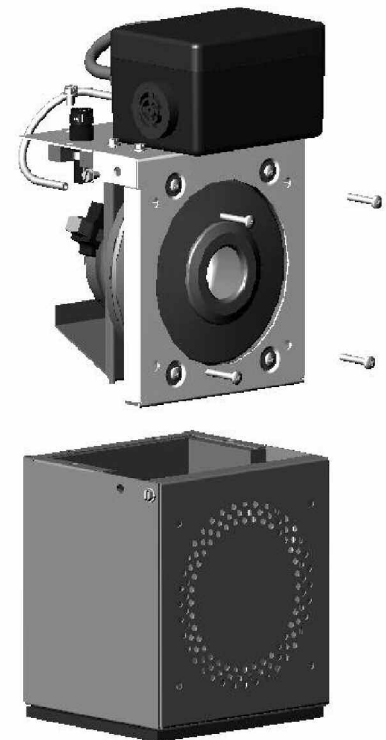

Figure 13 - Blower Removal

8. Equipment Specification

AIRaider EZ95 20 Amp 120 VAC System.

Blower: High Flow 20000 RPM 0.21HP 800 Watt 115VAC/5.7 Amp

Pump: 1 HP 1100 Watt 115V/9.8 Amp Thermally Protected Submersible

Pump Controller: Pressure Switch with Smart Valve to reduce Pump cycling on and off.

Air Alarm: Pressure Switch with 120 VAC/0.02 Amp Buzzer

Solenoid Valves: Normally Closed Metal Housed Class F120 VAC Buna N Seal Brass Valve Body 3/4" NPT

System Voltage: 115V

Electric Supply: 20 Amp 115VAC Dedicated Circuit.

Recommended Flow: Up to 7 GPM

Radon Reduction: Up to 95%+

Water Inlet/Outlet Connections: 3/4" Sharkbite to suit 3/4" Pex or Copper

Air Outlet: 2" PVC Pipe Female Socket (Solvent Cement)

Air Inlet: Via Filter/Silencer

Tank: Double Wall Insulated NSF Rated for Potable Water

Tank Dimensions: 27.62 " H x 25.17" W x 25.23" L

Tank Operating Capacity: 27 Gallons (Total Internal Volume 41 gallons)

Overall Dimensions: 36.37" H x 25.65" W x 25.71 L

Pipe: CPVC and Pex/Pex Fittings NSF Rated for Potable Water

Limited Warranty

Subject to applicable consumer protection legislation, Spruce Environmental Technologies, Inc. (Spruce) warrants that the AIRaider™ will be free from defective materials and workmanship for the period of two (2) years from the date of purchase.

Warranty is contingent on installation in accordance with the instructions provided. This warranty does not apply where repairs or alterations have been made or attempted by others; or the unit has been abused or misused. Warranty does not include damage in shipment unless the damage is due to the negligence of Spruce. To make a claim under these limited warranties, you must return the defective item to Spruce. All other warranties, expressed or written are not valid. Spruce is not responsible for installation or removal cost associated with this warranty. In no case is Spruce liable beyond repair or replacement of the defective product FOB Spruce.

SPRUCE SPECIFICALLY DISCLAIMS ANY WARRANTY OF FITNESS FOR A PARTICULAR PURPOSE.

THERE ARE NO WARRANTIES WHICH EXTEND BEYOND THE DESCRIPTION ON THE FACE HEREOF. THERE IS NO WARRANTY OF MERCHANTABILITY. ALL OTHER WARRANTIES, EXPRESSED OR WRITTEN, ARE NOT VALID.

In order to obtain service under this warranty, the consumer must contact the installer or dealer where the unit was purchased. The installer or dealer must then contact Spruce directly for a Return Merchandise Authorization (RMA) number and shipping information. **No returns can be accepted without an RMA.** Spruce may require the defective part(s) to be returned to place of manufacture (freight pre-paid) to process the warranty claim. Defective part(s) covered under this warranty will be replaced or repaired at the place of manufacture and returned to the installer or dealer (freight pre-paid). In replacing or repairing parts or products, Spruce reserves the right to make such changes in the details of design construction, arrangement or make materials as shall in its judgment constitute an improvement over former practice.

Record the following for your records:

Serial No. _____ Date Purchased: _____



3 Saber Way
P.O. Box 8244
Ward Hill, MA 01835
Phone: (800) 355-0901
Fax: (978) 521-3964
E-mail: sales@spruce.com



3 Saber Way
P.O. Box 8244
Ward Hill, MA 01835
Phone: (800) 355-0901
Fax: (978) 521-3964
E-mail: sales@spruce.com