

Instruction Manual

Series U

Electronic Metering Pumps



For file reference, please record the following data:

Model No: _____

Serial No: _____

Installation Date: _____

Installation Location: _____

When ordering replacement parts for your Pump or Accessory, please include the complete Model Number and Serial Number of your unit.

Uni-Dose™

201 Ivyland Road
Ivyland, PA 18974
TEL: (215) 293-0401
FAX: (215) 293-0445
www.lmipumps.com

Replaces same of Rev. C 7/01
1845. D 11/06

Contents

1.0 UNPACKING	3
2.0 PRE-INSTALLATION INSTRUCTIONS	4
2.1 Precautions	4
2.2 Chemical Compatibility Chart	6
3.0 INSTALLATION	7
3.1 Pump Location and Installation	7
3.2 Pump Mounting	7
3.2.1 Flooded Suction	8
3.2.2 Suction Lift	8
3.2.3 Injection into Well System	10
3.3 Tubing Connections	11
3.4 Foot Valve Tubing Installation	11
3.5 Injection Check Valve Installation	13
3.6 Bleed/Priming Valve	14
4.0 START-UP and ADJUSTMENT	15
4.1 Output Adjustment Controls	15
4.2 Start-Up / Priming	15
4.3 Output Adjustment	16
5.0 CALIBRATION	17
6.0 MAINTENANCE	19
6.1 Cleaning Liquid End (in place)	19
6.2 Cleaning Liquid End (disassembled)	20
6.3 Changing Liquifram	21
6.4 Liquid Handling Assembly Explod. View	22
6.5 Liquid Handling Assembly Parts List	23
6.6 Drive Assembly Parts List	24
6.7 Drive Assembly Explod. View	25
7.0 TROUBLESHOOTING	26

1.0 UNPACKING

Along with your pump, your carton will contain the following items. Please notify the carrier immediately if there are any signs of damage to the pump or its parts. Notify your pump supplier if any of the following parts are missing.

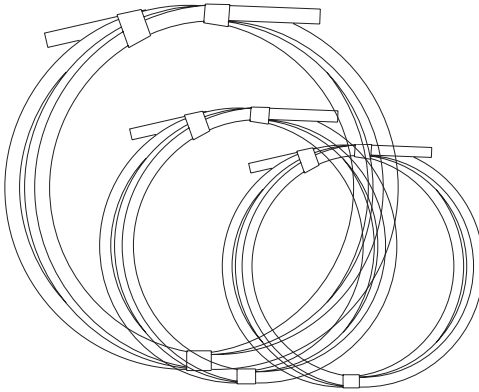

Tubing

Your carton will contain three (3) rolls of tubing. The clear vinyl tubing is for connection to the SUCTION SIDE OF THE PUMP HEAD ONLY.

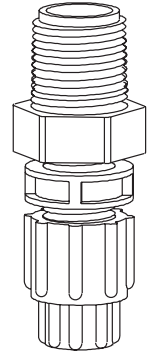

Injection Check Valve



Ceramic Foot Value Weight

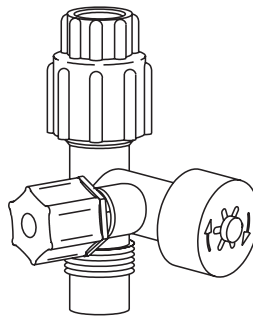

Bleed / Priming Valve

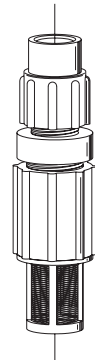

Foot Valve

2.0 PRE-INSTALLATION INSTRUCTIONS

The following precautions should be taken when working with chemical metering pumps. Please read this section carefully prior to installation.

2.1 Precautions



Protective Clothing

ALWAYS wear protective clothing, face shield, safety glasses and gloves when working on or near your metering pump. Additional precautions should be taken depending on the solution being pumped. Refer to MSDS precautions from your solution supplier.



Water Pre-Prime

All pumps are pre-primed with water when shipped from the factory. If your solution is not compatible with water, disassemble the Pump Head Assembly. Thoroughly dry the pump head, Uni-Valves, and Liquifram™ (diaphragm). Reassemble head assembly tightening screws in a crisscross pattern. Refill the pump head with the solution to be pumped before priming the pump (this will aid in priming).



Solution Compatibility

Please refer to the Chemical Compatibility Chart on page 6 for the materials of construction of your pump. Should you have any further compatibility questions on your pump, please call your local distributor.



Tubing Connections

Inlet and outlet tubing sizes must not be reduced. Make certain that all tubing is **SECURELY ATTACHED** to fittings prior to start-up. (See Section 3.3, Tubing Connections). **ALWAYS** use the supplied tubing with your pump, as the tubing is specifically designed for maximum compatibility with the pump operation. It is recommended that all tubing be

shielded to prevent possible injury in case of rupture or accidental damage.



Fittings And Machine Threads

All fittings should be hand tightened to a maximum of $\frac{1}{8}$ to $\frac{1}{4}$ turn after the fitting contacts the Uni-Valve. **DO NOT OVERTIGHTEN FITTINGS.** Overtightening or use of a pipe wrench can cause damage to the fittings, Uni-Valves, or pump head, causing the pump to **LOSE PRIME OR NOT FUNCTION.**

DO NOT use Teflon tape or pipe dope to seal threads. **Teflon Tape may only be used on the 1/2" NPT thread side of the Injection Check Valve** before installing in a pipe line or tee.



Plumbing

Always adhere to your local plumbing codes and requirements. Be sure installation does not constitute a cross connection. Check local plumbing codes for guidelines. The factory is not responsible for improper installations.



Electrical Connections

WARNING: to reduce the risk of electrical shock, install only on a circuit protected by a ground-fault circuit-interrupter (GFCI). The metering pump must be plugged into a grounded outlet with ratings conforming to the data on the pump control panel. The pump must be connected to a good ground. **DO NOT USE ADAPTERS!** All wiring must conform to local electrical codes.

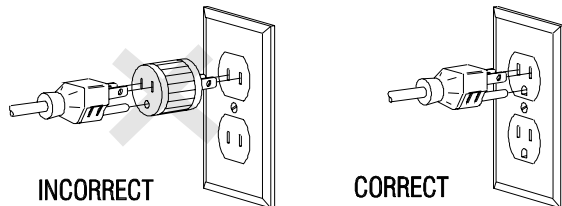

Figure 1: Electrical Connections

2.2 CHEMICAL COMPATIBILITY CHART

These pumps are designed specifically for water conditioning. Other applications may require the use of chemicals not compatible with the materials of construction of these chemical metering pumps.

Materials of Construction	
Flexiprene - <i>a thermoplastic elastomer vulcanizate</i>	Polypropylene
Macroflex - <i>an elastomeric copolymer</i>	Noryl
PVC - <i>polyvinyl chloride</i>	U.V. Resistant Polyethylene

Chemical compatibility of this pump with the following solutions is rated as good. For chemicals not listed, please contact your local representative or the factory.

Alum	Sodium Carbonate
Calcium Hypochlorite	Sodium Hydroxide
Muriatic Acid (<i>5% Hydrochloric Acid</i>)	Sodium Hypochlorite
Polyphosphates	Sodium Hexametaphosphate
Potassium Permanganate, 10%	Sodium Phosphate
Sodium Bicarbonate	Sodium Thiosulfate
	Vinegar

DISCLAIMER OF WARRANTY AND LIABILITY

Although the information set forth herein is presented in good faith and believed to be correct on the date of issuance, Liquid Metronics Division, Milton Roy Company makes no guarantee or representation as to the completeness or accuracy thereof, and disclaims all liability for any loss or damage resulting from use or reliance upon any information, recommendations or suggestions contained herein. LIQUID METRONICS DIVISION, MILTON ROY MAKES NO EXPRESS OR IMPLIED REPRESENTATIONS OR WARRANTIES AS TO THE FITNESS, MERCHANTABILITY, OR ANY OTHER MATTER WITH RESPECT TO THE INFORMATION CONTAINED HEREIN OR ANY PRODUCT OR SUBSTANCE REFERRED TO HEREIN, whether used alone or in combination with any other material. Nothing contained herein is to be construed as a recommendation to use any product in conflict with any patent.

The data in all tables are based on samples tested and are not guaranteed for all samples or other applications. Write to us for our current sales specifications.

3.0 INSTALLATION

3.1 Pump Location and Installation

Locate pump in an area convenient to the solution tank and electrical supply.

The pump should be accessible for routine maintenance, and should not be subjected to ambient temperatures above 110° F (43° C). If the pump will be exposed to direct sunlight, black UV resistant tubing should be installed.

3.2 Pump Mounting

Common Errors

To avoid siphoning, do not install your pump so that it pumps downhill or into the suction side of a pump.

Your chemical metering pump must be mounted so that the suction and discharge valves are vertical. **NEVER position pump head and fittings horizontally.**

Rubber Pad Placement

To help reduce the noise of your pump, we recommend installing the four (4) rubber foot pads as illustrated here:

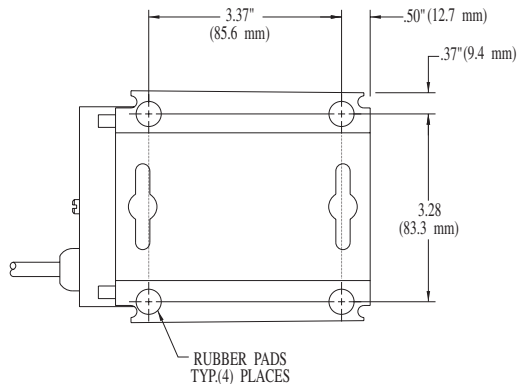

Figure 2: Rubber Pad Replacement

The pump can be mounted in one of two ways:

3.2.1 Flooded Suction (Ideal Installation)

The pump is mounted at the base of the storage tank. This installation is the most trouble-free, and is recommended for very low outputs, solutions that gasify, and high viscosity solutions. Since the suction tubing is filled with solution, priming is accomplished quickly and the chance of losing prime is reduced.

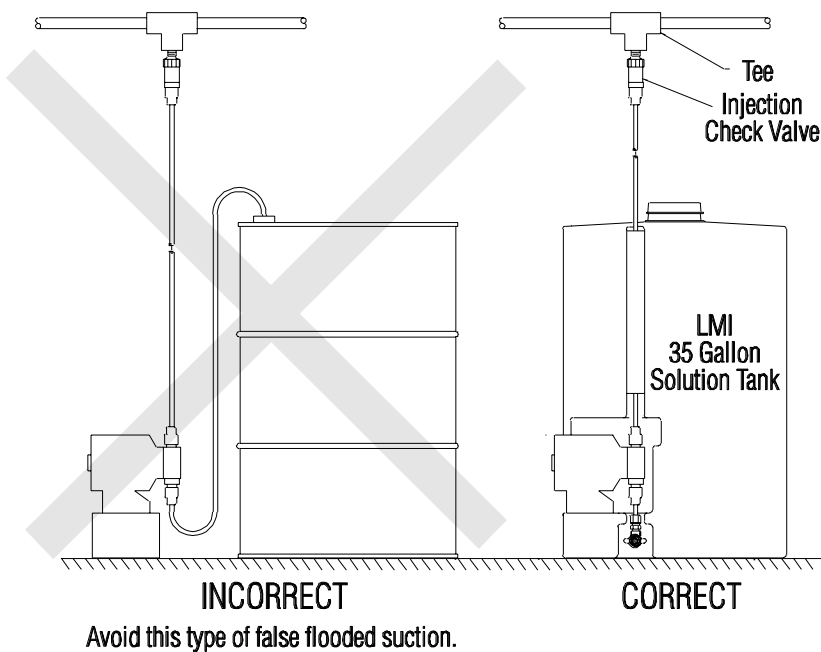

Figure 3: Flooded Suction Installation



DO NOT immerse pump in solution

3.2.2 Suction Lift

Maximum suction lift is 5 ft (1.5 m) for solutions having the specific gravity of water. For denser solutions, consult the factory.

Suction Lift - Wall Bracket Mount

The pump may be mounted using a Wall-Mount Bracket Assembly (part no. 34643) directly above the solution tank. A pump mounted in this manner allows for easy changing of solution tanks or drums.

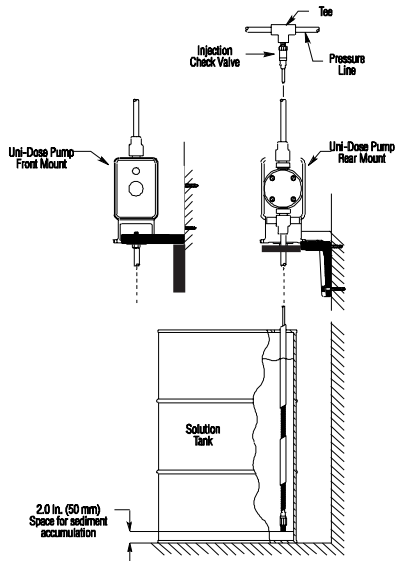

Figure 4: Wall Bracket Mount

Suction Lift - Tank Mount

The pump may be mounted on a molded tank, 15-gallon tanks (part no. 34054) and 35-gallon tanks (part no. 34055) are suitable for pump mounting.

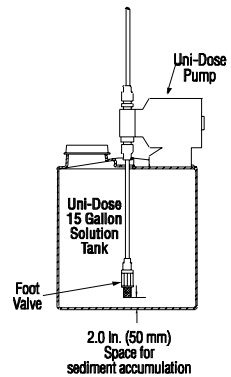
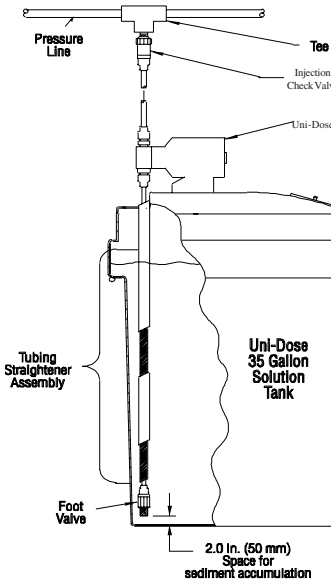

Figure 5: Tank Mount

Suction Lift - Shelf Mount

The pump may be mounted on a shelf (customer supplied) maintaining a suction lift of less than 5 ft (1.5 m). A Uni-Dose mounting kit (part number 10461) is available for securing the pump to a shelf.

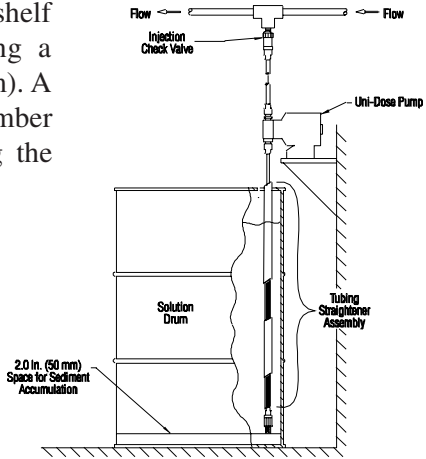

Figure 6: Shelf Mount

3.2.3 Injection into a Well Pump System

If the pump is to be used in conjunction with a well pump, the voltage of the pump must match the voltage of the well pump. Install the injection check valve of your pump into a pipe tee that is installed in the water line going to the pressure tank. The injection valve must be installed vertically (arrows pointing upward) on the bottom side of the water line to prevent backflow into the pump's discharge line.

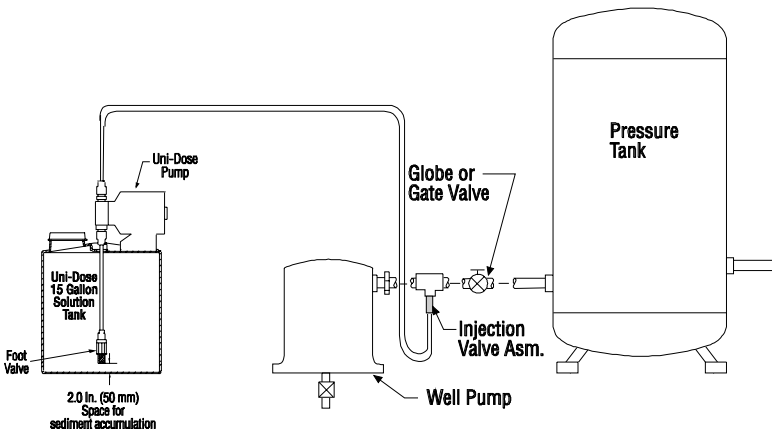

Figure 7: Well Pump System

3.3 Tubing Connections

A. Use only the supplied tubing.



B. DO NOT USE CLEAR VINYL TUBING ON THE DISCHARGE SIDE OF THE PUMP.

The pressure created by the pump can rupture the vinyl tubing.

C. Before installation, all tubing must be cut with a clean square end.

D. Valve and head connections from the factory are capped or plugged to retain pre-prime water. Remove and discard these caps or plugs before connecting tubing.

DO NOT USE PLIERS OR PIPE WRENCH ON COUPLING NUTS OR FITTINGS.

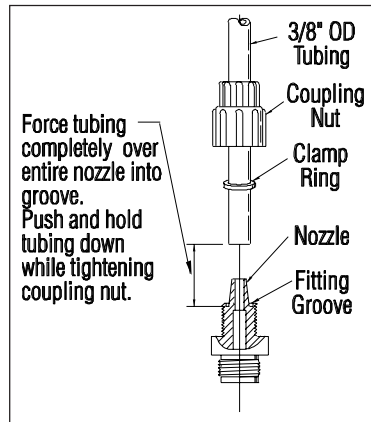

Figure 8: Tubing Connections

3.4 Foot Valve/Ceramic Weight Installation

The foot valve acts as a check valve to keep the pump primed in suction lift applications.

The foot valve is designed to be submersed in the solution tank or drum and must sit in a vertical position at the bottom. Position approximately two 2 inches (50 mm) off the bottom if the tank or drum contains sediment.

The suction tubing straightener, when assembled, positions the foot valve and suction tubing in a vertical position.

1. Attach the foot valve to one end of the suction tubing (see Tubing Connections, section 3.3).
2. Slide the ceramic weight over the tubing end until it contacts the top of the foot valve coupling nut.
3. Place foot valve, tubing and suction tubing straightener into the solution tank. Check that the foot valve is vertical and approximately two (2) inches (50 mm) from the bottom of the tank or drum (see figure 9). Connect the other end of the tubing to the suction side of the pump head (bottom side).

Proper Foot Valve Position

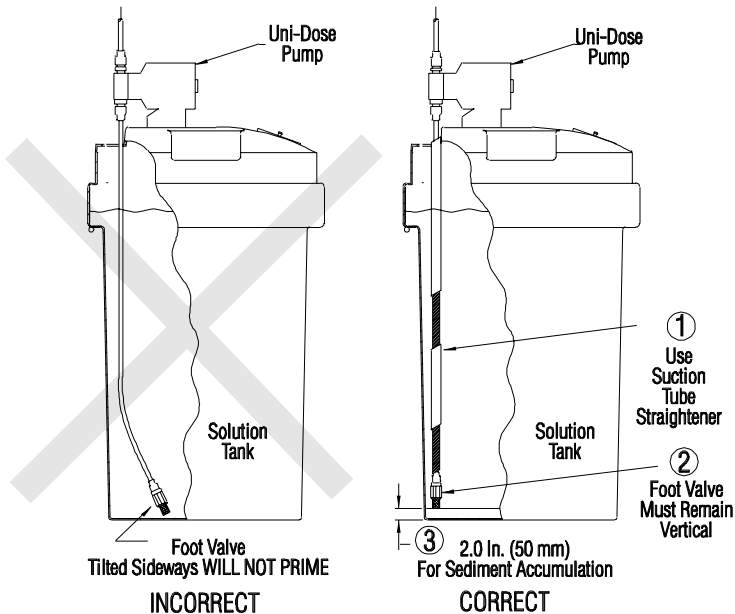

Figure 9: Foot Valve Position

3.5 Injection Check Valve Installation

The Injection Check Valve prevents backflow from a treated line. Connect the Injection Check Valve to your “DISCHARGE” (outlet) line. Any size NPTF fitting or pipe tee with a reducing bushing to 1/2" NPTF will accept the injection check valve. Use Teflon tape or pipe dope to seal the pipe threads only.

When installing the Injection Check Valve, be sure to position it so that the valve enters the bottom of your pipe in a vertical position. Variations left and right within 80° are acceptable (see figure 10).

After cutting an appropriate length of tubing, connect tubing to the injection check valve then back to the discharge side of the pump head (top side), making sure it does not crimp or come in contact with hot or sharp surfaces.

Typical Injection Check Valve Installations

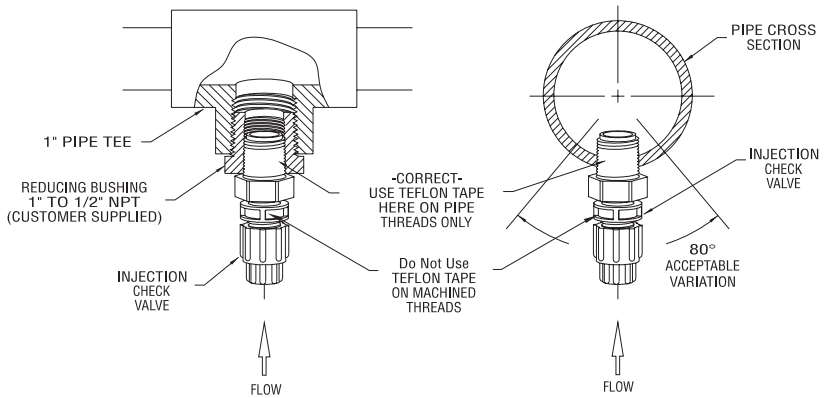

Figure 10: Calibration

3.6 Bleed / Priming Valve

These pumps include a bleed/priming valve assembly which may be installed on the discharge side of the pump head (see section 6.4). This valve will allow you to de-pressurize the discharge tubing without disconnecting the tubing from the fittings, which simplifies priming. Be sure to connect the solution return line as shown below:

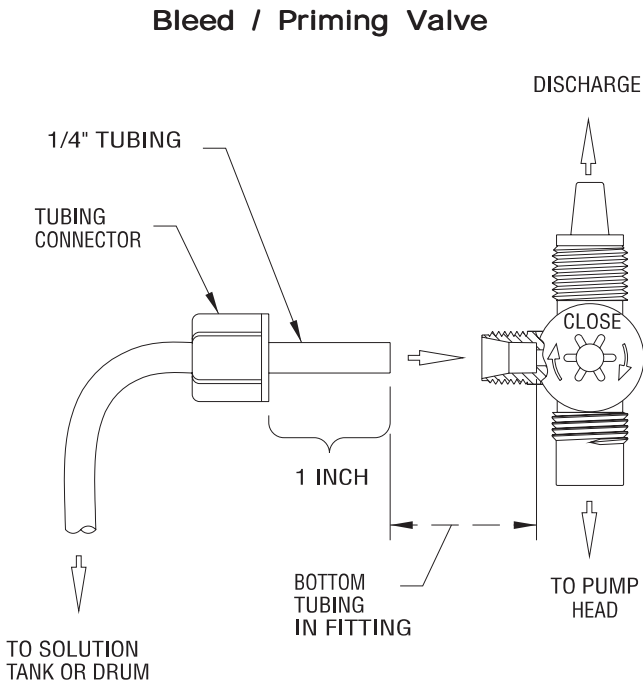

Figure 11: Bleed / Priming Valve



Warning: The return line must be secured to insure pumped solution will return to supply tank. **DO NOT** submerge return line in solution.

4.0 START-UP and ADJUSTMENT





The pump is normally self-priming if suction lift is 5 ft (1.5 m) or less, and the steps below are followed.



Pumps are shipped from the factory with water in the pump head to aid in priming.

4.1 Output Adjustment Controls

Note: These pumps are available with speed and stroke adjustment or with stroke adjustment only.

1. **Speed Adjustment:** Speed control provides adjustment of the percent of maximum strokes per minute. Turning this knob clockwise  increases stroke frequency.
2. **Stroke Adjustment:** Stroke control provides adjustment of percent of maximum Liquifram (diaphragm) travel. Turning this knob clockwise  increases percent output per stroke.

4.2 Start-Up/Priming



Read this entire section completely before proceeding.

When all precautionary steps have been taken, the pump is mounted, and the tubing is securely attached, you may now prime the pump.

1. Plug the pump in.
2. While the pump is running, set the speed knob (if equipped) at 80% and the stroke knob at 100%.
3. Open bleed/priming valve, if installed, by turning knob counter-clockwise.

4. The suction tubing should begin to fill with solution from the tank.
5. Once a solid stream of solution begins to exit the pump head or return tubing on the bleed/priming valve, close valve by turning knob clockwise. Disconnect the power cord.
6. The pump is now primed.
7. Proceed to output adjustment, Section 4.3.



If the pump does not self-prime, remove the fitting or bleed/priming valve on the discharge side of the pump head. Remove the Uni-Valve and pour water or solution into the port until the head is filled. Replace valve, then follow start up/priming steps.

4.3 Output Adjustment

Once the pump has been primed, an appropriate output adjustment **MUST** be made, pump output should be calculated and adjustments made accordingly.

Calculate the total output of the pump as follows:

$$\text{PUMP OUTPUT} = \text{MAX PUMP OUTPUT} \times \% \text{SPEED} \times \% \text{STROKE}$$

Example: U131-281

Use MAX Output (From dataplate on bottom center of pump control panel) = 24 GPD (gallons per day).

If the pump is set at 60% speed and 70% stroke length, the approximate pump output is:

$24.0 \times 0.60 \times 0.70 = 10.08$ GPD (gallons per day) Divide by 24 (hours in one day) to calculate GPH (gallons per hour).



*If pump is not equipped with speed adjustment, calculate by **Max Pump Output x % Stroke** only.*

5.0 CALIBRATION

Once installation is complete and the approximate output has been determined, the pump may be calibrated to adjust speed (if equipped) and stroke for your actual desired output.

1. Be sure the pump is primed, and discharge tubing and Injection Check Valve are installed as they would be in normal service (i.e., including factors such as injection pressure, fluid viscosity, and suction lift).
3. Place the foot valve in a graduated container with a volume of 1000 ml or more.
4. Start the pump and run until all the air is exhausted from the suction line and head.
5. Disconnect power to the pump. Refill graduated container to a level starting point.

6. Using a stopwatch or timer, start the pump and run for a measured amount of time (50 pump strokes minimum). The longer the time period, the more confident you can be of the results. Be sure to count the number of strokes during the calibration period when making comparisons.
7. Disconnect power to the pump. Note the time elapsed in relation to volume displaced in the graduate. Now, calculate the output in the time unit you choose (minutes, hours, days, etc.).
8. If the output is too low or too great, adjust speed and/or stroke, estimating required correction and repeat steps 1-7.

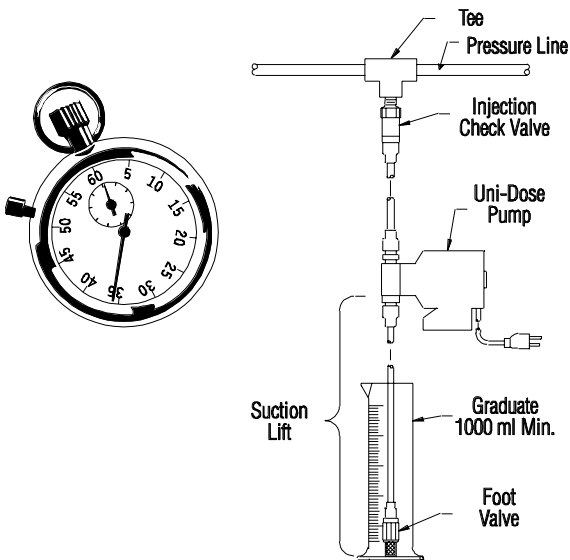

Figure 12: Calibration

6.0 MAINTENANCE



WARNING: ALWAYS wear protective clothing, face shield, safety glasses and gloves when performing any maintenance or replacement on your pump. Read this entire section before proceeding.



WARNING: Extreme care should be taken to avoid spilling any solution from the tubing during these procedures.

6.1 Cleaning Liquid End (In-Place)

Many water conditioning additives tend to be alkaline and scale forming. The following cleaning procedure may be used as often as necessary to ensure proper performance from your pump:



WARNING: DO NOT USE WATER TO FLUSH LIQUID END IF YOUR SOLUTION REACTS WITH WATER.

1. Turn off the metering pump. Carefully lift the foot valve out of the solution tank and place it in a container of water. Carefully depressurize and disconnect the discharge line from the injection check valve and place the end of the tubing in the an empty container. Turn the pump on to flush the head and tubing with clear water.



The metering pump should be turned off when moving the foot valve from one container to another in order to prevent air from entering the pump head and possibly causing loss of prime.

2. Again turn off the metering pump. Lift the foot valve out of the container of water and place it in a container of cleaning solution. Turn on the metering pump and let it pump for approximately five (5) minutes or until any scale is dissolved.
3. Turn off the metering pump and transfer the foot valve to the container of water. Turn the pump on for long enough to flush the cleaning solution from the head and tubing. Turn pump off and return the foot valve to the solution tank. Reconnect the discharge tubing to the injection check valve.

4. Turn the pump on and let it pump at full output for approximately one minute, then return the output to the normal operating setting.

6.2 Cleaning Liquid End (Disassembled)

If the solution being pumped forms deposits which cannot be cleaned in-place with the cleaning solution, the head and valves should be disassembled and cleaned, as frequently as experience indicates is necessary, as follows:



WARNING: DO NOT USE WATER TO FLUSH LIQUID END IF YOUR SOLUTION REACTS WITH WATER.

1. Turn off the metering pump. Carefully depressurize and disconnect the discharge line from the injection check valve and place the end of the tubing in an empty container. Carefully lift the foot valve out of the solution tank and place it in a container of water. Turn the pump on to flush the head and tubing with clear water. Turn the pump off. Disconnect tubing from the suction and discharge valves at pump head.
2. Remove head by unscrewing four (4) pump head mounting screws.
3. Unscrew valve fittings and remove Uni-valves from fittings.



Care should be taken when removing and cleaning valves to prevent damage to any sealing surface. DO NOT PINCH OR OTHERWISE DEFORM THE UNI-VALVE. DO NOT SCRATCH THE SURFACE OF THE LIQUIFRAM (diaphragm).

4. Soak and clean all Uni-valves with a suitable cleaning solution.
5. Inspect all valves and Liquifram (diaphragm) for imperfections. Replace as necessary. A spare parts kit **SP-281** should be installed as often as necessary, at least once every twelve (12) months.
6. Assemble valves and head assembly exactly as shown in the exploded view. Tighten head screws in a crisscross pattern to 30 in-lbs. **DO NOT OVERTIGHTEN.**



If valves are dirty or not assembled exactly as shown in the exploded view, the pump will not operate.

6.3 Changing Liquifram (diaphragm)

1. Follow steps 1 & 2 of **Cleaning Liquid End (Disassembled)** in Section 6.2.
2. Adjust stroke length knob to 20% by rotating counter-clockwise with the pump operating. Stop pump by unplugging cord set.
3. Grasp outer edge of Liquifram (diaphragm) with your fingers and rotate counterclockwise until removed.



Before installing new Liquifram (diaphragm) be sure disk is properly installed in EPU assembly.

4. Install new Liquifram (diaphragm) by screwing it onto the threaded shaft until it bottoms. **DO NOT SCRATCH THE SURFACE OF THE NEW LIQUIFRAM** (diaphragm).
5. Set stroke adjustment knob to 100% before reinstalling pump head. Tighten four (4) head screws in a crisscross pattern to 30 in-lbs. **DO NOT OVERTIGHTEN.**

6.4 Liquid Handling Assembly LE-281 Exploded

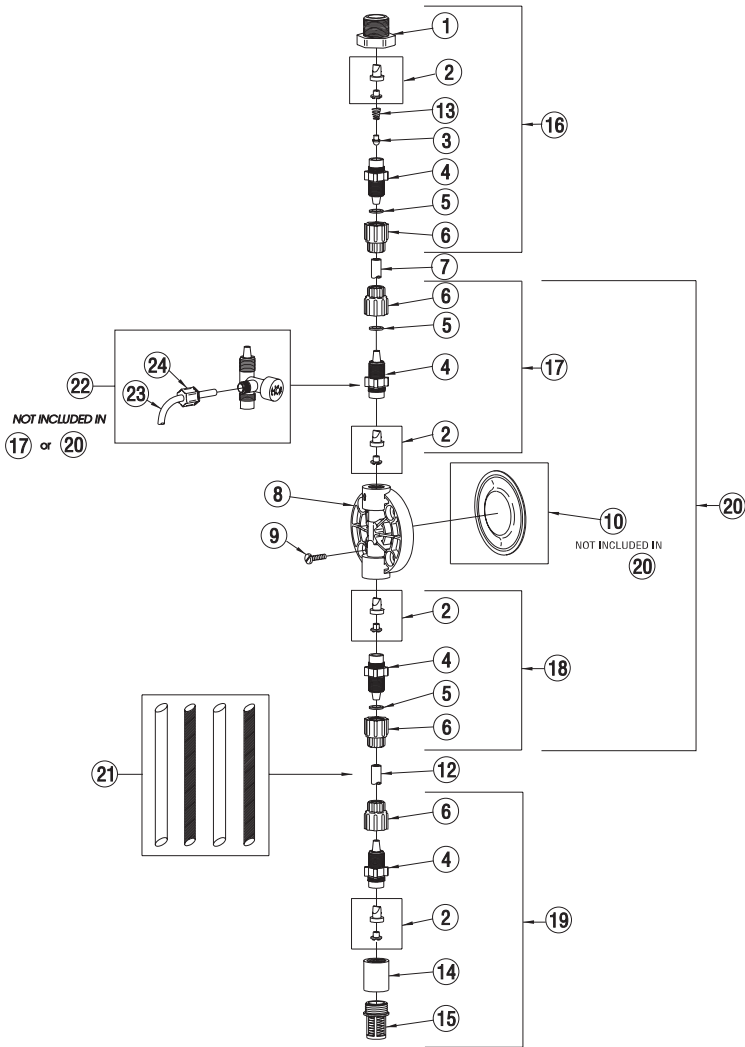

6.5 Liquid Handling Assembly LE-281 Parts List

KEY NO.	PART NO.	DESCRIPTION	QUANTITY
			LE-281
1	30999	Injector Fitting, Noryl	1
2	30995*	Uni-Valve Asm.	4
3	31623*	Seal, Flexprene	1
4	30620	Valve Housing, PVC	4
5	26136	Clamp Ring	3
6	10299	Coupling Nut	4
7	27342-10	Tubing, .375" O.D. Black Polyethylene	1
8	31900	Head, 0.8 SI, PVC	1
9	10340	Screw, 10-24 x 3/4" S.S.	4
10	30981*	Liquifram, 0.8 SI, Flexiprene	1
12	10469-06	Tubing, .375" O.D., Vinyl	1
13	31565*	Spring, Hastelloy	1
14	30840	Foot Valve Seat	1
15	10123	Strainer, Polypropylene	1
16	31635	Injector Check/Back Pressure Valve Asm.	1
17	30986	Discharge Valve Assembly	1
18	30987	Suction Valve Assembly	1
19	30988	Foot Valve Assembly	1
20	30989	Head Assembly, LE-281	1
21	32293	Tubing Straightener	1
22	34744	Bleed/Priming Valve	1
23	25636-10	Tubing, .250" OD PE	1
24	25631	Coupling Nut	1

*Parts included in Spare Parts Kit SP-281

6.6 Drive Assembly Parts List

Key No.	Model	Part No.	Description	Qty.
1	U	30827	Disk	1
2	U	10973	Seal	1
3	U011,U021, U031, U041 U121, U131, U141	32370R	EPU	1
	All 230V Models	32371R	EPU	1
4	U	10166	O-Ring	1
5	U	32367	Bumper	1
6	U	10422	Retaining Ring	1
7	U	25963	Washer, Nylon	1
8	U	30391	Washer, Rubber	1
9	U1	35744	Dual Pin	1
10	U0	36254	Pulser	1
	U1	36255	Pulser	1
11	U1	35743	Speed Shaft	1
12	U1	34497	O-Ring	1
13	U	25414	Spring	1
14	U1	30803	Gasket	1
15	U1	30709B	Speed Knob	1
16	U	30306	Screw	4
17	U011, U021, U031, U041 U121, U131, U141	10626	Varistor Assembly, 115V	1
	U012, U022, U032, U042 U122, U132, U142	31255	Varistor Assembly, 230V US	1
	U013, U023, U033, U043 U123, U133, U143 U015, U025, U035, U045 U125, U135, U145 U016, U026, U036, U046 U126, U136, U146 U017, U027, U037, U047 U127, U137, U147	10627	Varistor Assembly, 230-250V	1
18	U01, U03	31044	Stroke Dial	1
	U02, U12	36178	Stroke Dial	1
	U04, U14	33876	Stroke Dial	1
19	U	30295B	Stroke Knob	1
20	U01	31066	Resistor Assembly	1
	U02	29797	Wire Assembly	1
	U	32357	Rubber Foot Pad (not shown)	4

6.7 Drive Assembly Exploded View

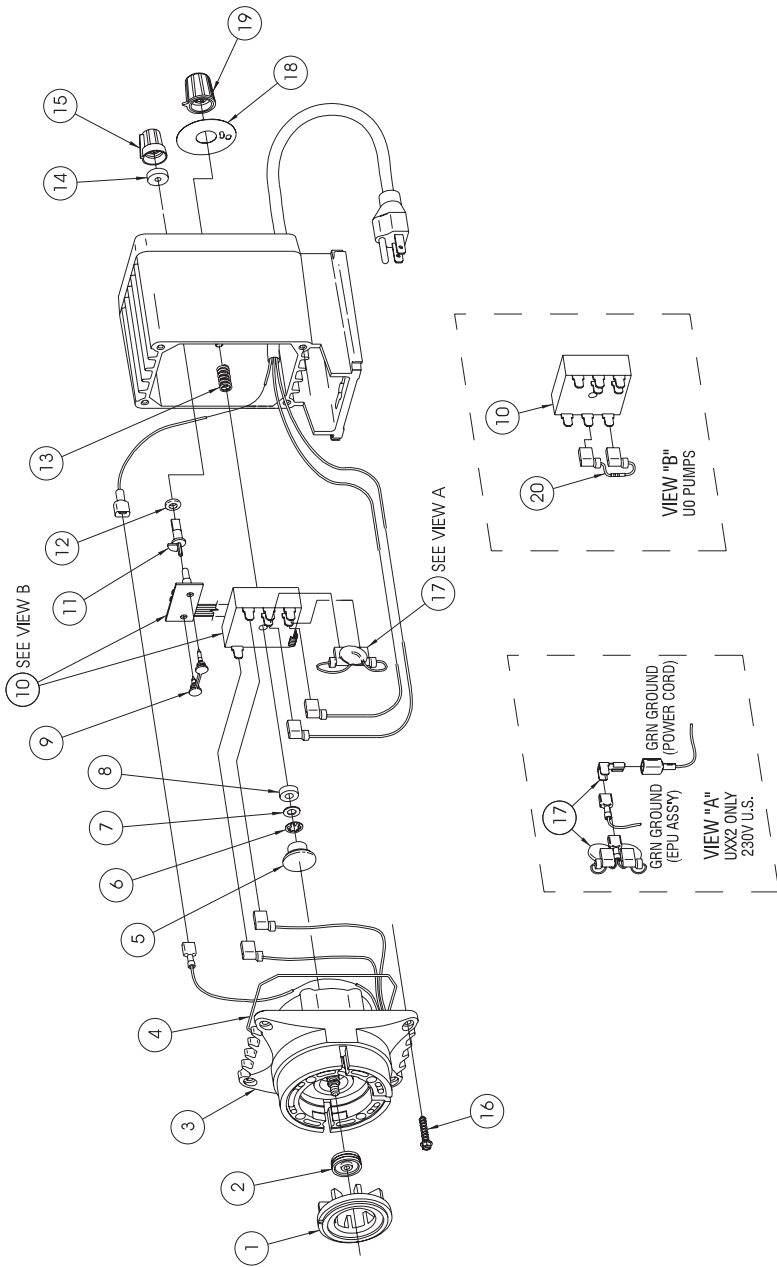

7.0 TROUBLESHOOTING

PROBLEM	POSSIBLE CAUSE
Pump Will Not Prime	1. Pump not plugged in to live outlet.
	2. Output knobs not set properly.
	3. Foot Valve not in vertical position on bottom of tank.
	4. Pump suction lift too high.
	5. Suction tubing is curved or coiled in tank
	6. Fittings are over-tightened.
	7. Air trap in suction tubing.
	8. Too much pressure at discharge.
Pump Loses Prime	1. Solution container ran dry
	2. Foot Valve is not in a vertical position on the bottom of the tank.
	3. Pump suction lift is too high.
	4. Suction tubing is curved or coiled in tank.
	5. Fittings are overtightened.
	6. Air trap in suction valve tubing.
	7. Air leak on suction side.

SOLUTION

1. Check outlet/plug in pump.
 2. Always prime pump with speed at 80% (if equipped) and stroke at 100%.
 3. Foot Valve must be vertical (See Foot Valve Installation, Section 3.4).
 4. Maximum suction lift is 5 ft (1.5 m) Reduce suction lift or change to flooded suction.
 5. Suction tubing must be vertical. Use tubing straightener supplied with pump. (See Section 3.4)
 6. Do not overtighten fittings. This causes valves to distort and not seat properly which causes pump to leak back or lose prime.
 7. Suction tubing should be as vertical as possible. AVOID FALSE FLOODED SUCTION! (See Section 3.2.1)
 8. Check for closed valves or blockage in pressurized line. Eliminate problem and reprime pump if necessary (See priming Section 4.2). When pump is primed, reconnect discharge tubing.
-
1. Refill container with solution and reprime (See Section 4.2)
 2. Foot Valve must be vertical (See Foot Valve Installation, Section 3.4).
 3. Maximum suction lift is 5 ft (1.5 m). Reduce suction lift or change to flooded suction.
 4. Suction tubing must be vertical. Use tubing straightener supplied with pump. (See Section 3.4)
 5. Do not overtighten fittings. This causes valves to distort and not seat properly which causes pump to leak back or lose prime.
 6. Suction tubing should be as vertical as possible. AVOID FALSE FLOODED SUCTION! (See Section 3.2.1)
 7. Check for pinholes, cracks in tubing. Replace if necessary.
-

TROUBLESHOOTING (continued)

PROBLEM	POSSIBLE CAUSE
Leakage at tubing	1. Worn tubing ends.
	2. Loose or cracked fitting.
	3. Worn Uni-Valves.
	4. Solution attacking Liquid Handling Assembly material.
Low Output or Failure to Pump Against Pressure	1. Pump's maximum pressure rating is exceeded by injection pressure.
	2. Worn Uni-Valves.
	3. Ruptured Liquifram.
	4. Tubing run on discharge may be too long.
	5. Clogged foot valve strainer.
Failure to Run	1. Pump not plugged in to live outlet.
	2. EPU failure.
	3. Pulser failure.
Excessive Pump Output	1. Siphoning.
	2. Little or no pressure at injection point.
	3. Excessive strokes per minute.

REMEDY

1. Cut about 1 in (25 mm) off tubing and then replace as before.
2. Replace fitting if cracked. Carefully hand tighten fittings. Do not use pipe wrench. Once fitting comes into contact with valve, tighten an additional 1/8 or 1/4 turn.
3. Replace Uni-Valves. (See Section 6.2) Spare Parts (SP-281)
4. Consult Chemical Compatibility Chart (Sec. 2.2) or factory.

-
1. Injection pressure cannot exceed pump's maximum pressure. See pump dataplate.
 2. Worn Uni-Valves may need replacement. (See Section 6.2) Spare Parts (SP-281)
 3. Replace Liquifram. (See Section 6.3).
 4. Longer tubing runs may create frictional losses sufficient to reduce pump's pressure rating. Consult factory for more information.
 5. Remove foot valve strainer, clean and reinstall.

-
1. Check outlet, plug in pump.
 2. Disassemble pump and measure the resistance of the EPU across the EPU wires. Resistance reading should be 76-87 Ohms at 20°C /68° F (115VAC pump) or 307-353 Ohms at 20° C/ 68° F (230VAC pump). Also check EPU leads to ground. Consult supplier or factory.
 3. The pulser should be replaced if EPU checks out OK. Consult supplier or factory.

-
1. Move injection point to a pressurized location.
 2. Make sure spring loaded injection check valve is installed properly.
 3. Replace pulser, resistor, or wire assembly. Consult factory.
-

OPTIONAL ACCESSORIES

To complete your installation, the following accessories are available:

SOLUTION TANKS

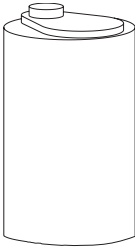

Model 34054
15-Gallon White
Polyethylene Tank

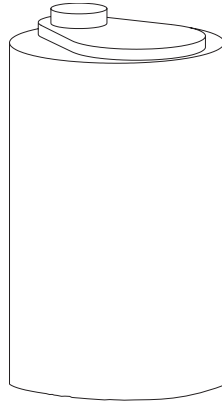

Model 34055
35-Gallon White
Polyethylene Tank

AGITATORS

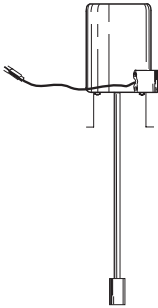

Model 27591
Agitator, 115V
(For use with Model 34055 tank)

WALL-MOUNT BRACKET

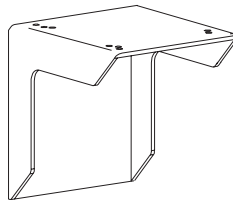

Model 34643
Wall-Mount Bracket

Uni-Dose™

201 Ivyland Road
Ivyland, PA 18974
TEL: (215) 293-0401
FAX: (215) 293-0445
www.lmipumps.com