



Installation & Operation Manual

AIRRaider 433-S Series



3 Saber Way
Ward Hill, MA 01835

Table of Contents

1. PRE-INSTALLATION	3
1.1. Safety Matters	3
1.2. Water Flow Requirements.....	4
1.3. Unpacking and Locating System Components	5
1.3.1. Unpack All System Components.....	5
1.3.2. Locate All Components.....	5
1.4. Use Qualified Technicians.....	5
1.5. Full Water Test.....	5
2. INSTALLATION INSTRUCTIONS	6
2.1. System Location.....	7
2.2. Readyng the AIRaider™ for Installation	7
2.3. Plumbing Hook-up.....	9
2.4. Electrical Hook-up.....	10
2.5. Vent Line Installation.....	13
2.6 Air Filter.....	14
2.6.1 Remote Air Intake.....	14
2.7. System Start-up.....	14
2.8. System Check.....	15
3. RETESTING	16
4. MAINTENANCE	16
4.1. Six-Month Service (recommended).....	16
4.2. Annual Service (required).....	17
5. TROUBLE SHOOTING	18
LIMITED WARRANTY	19

Table of Figures

Figure 1 – Typical System	6
Figure 2 – Bypass/Solenoid Assembly	7
Figure 3 – Diagram of Installed System	8
Figure 4 – Water Connections.....	9
Figure 5 – 433-S75 Wiring Diagram.....	11
Figure 6 – 433-S50 Wiring Diagram.....	12
Figure 7 – Vent Line Connection.....	13
Figure 8 – Vent Line Installation (2 inch)	13
Figure 9 – Vent Line Installation (3 inch)	13
Figure 10 – Air Intake Connection	13
Figure 11 – Air Filter.....	14
Figure 12 – Installed AIRaider™ 433-S.....	14

1. Pre-Installation

The AIRRaider™ Systems are diffused bubble aeration systems for the removal of radon and other VOCs from residential and municipal water supplies. This installation/operation manual is designed to guide professionals through the safe and proper installation of the AIRRaider™ Systems.

Before beginning the installation of the AIRRaider™ System, there are 5 items to be considered. They are:

1. Safety
2. Installation site requirements
3. Inspection of System components
4. Qualified Technicians are necessary
5. Knowledge of all contaminants in the water

1.1. Safety Matters

Safety is the most important step in the installation process. Never perform any step of the installation that you are not qualified to perform (i.e. electrical or plumbing hook up). It is important that you read through the entire manual prior to beginning the installation. When performing the installation, work slowly and deliberately. Follow all instructions carefully and never take shortcuts. Our team of technicians are available to answer your questions at 800-355-0901.



WORK SAFELY!

1.2. Water Flow Requirements

The standard residential AIRraider™ Systems are designed for use with water flows up to 20 gallons per minute (GPM).* The system should be installed with an outflow ball valve. If higher/lower system outflow is needed, open/close the ball valve by the amount necessary to balance the system. The well pump output must produce at least 1 GPM more than the output of the AIRraider™ (i.e. well output = 8 GPM ; AIRraider™ outflow setting = 7 GPM) for proper system performance. If the well pump output is less than the system output the AIRraider™ will run dry and possible damage may occur. To prevent this from occurring the water flow rate must be determined before the system is installed.

**Some AIRraider™ Systems are not recommended for high flow residential properties. Repressurization systems (except for the AIRraider™ EZ⁹⁵ and S-Series) are sold separately. Proper repressurization system sizing is required to meet water flow needs. Consult manufacturer if assistance is needed for system selection.*

In order to determine available water flow rate the following are needed:

- Garden Hose
- Five Gallon Bucket
- A Stop Watch or Watch with a Second Hand

Or

- A Water Flow Meter

Household water use must be discontinued during the following flow rate test.

Mid-Range Flow Rate Test:

1. Attach garden hose to the drain connection on the base of the well pressure tank.
2. Open the drain valve and run water for 15 minutes.
3. After 15 minutes, check the pressure gauge on the well system. Adjust the drain valve (open or close) as needed to maintain the required running system pressure (constant pressure on gauge) with the well pump running continuously.
4. Run for 5 minutes while ensuring that the pressure is not fluctuating.
5. Run water from the hose into a five gallon bucket. Using a stop watch, time how many seconds it takes to fill the bucket (X sec.).
6. Determine the GPM by dividing 60 seconds by the number of seconds it took to fill the bucket (X sec.). Multiply the answer by 5 gallons. This gives you the GPM. $GPM = (60 / X) \times 5$
7. Repeat steps 5 and 6 and average the 2 numbers. The answer is the well pump output in gallons per minute. It is recommended that this number be indelibly recorded in an obvious location, together with the date of test, as it will be required when setting the AIRraider™ System and may be required for future troubleshooting of the well pump system or the AIRraider™ System.

1.3. Unpacking and Locating System Components

1.3.1. Unpack All System Components

Remove all packing material and discard appropriately away from the work area.

1.3.2. Locate All Components

Check to ensure all components are intact and undamaged from shipment.

Included Component List (may vary with order)

- Tank Assembly
- Control Panel and Float Switches
- Installation Kit – pressure gauge, manual, etc.
- Systems are equipped for $\frac{3}{4}$ " plumbing connection
- Submersible Pump

1.4. Use Qualified Technicians

A Licensed Plumber, Electrician, Contractor and/or Certified Water Treatment Specialist may be required to install the AIRRaider™ System in accordance with the installation instructions. All wiring must be performed in accordance with the National Fire Protection Association's (NFPA) "National Electrical Code, Standard #70" - current edition-for all commercial and industrial work. All wiring must be performed by a qualified and licensed electrician. Check your Local and State Code and Licensing requirements. Failure to follow the instructions may lead to poor system performance and/or possible system damage.

**The Installation must comply with all applicable Local and State Codes
and NFPA National Electrical Code, Standard #70.**

1.5. Full Water Test

A full Water Sample Analysis must be performed to determine the quality of the water that requires treatment. In many water supplies, contaminants other than Radon are present and may need to be pre-treated in order for the AIRRaider™ to work properly. The AIRRaider™ System is only effective for the removal of Radon and some other VOCs. The Aeration Process employed by the AIRRaider™ System and other Radon removal systems can worsen problems due to iron or manganese contaminants in the water supply. For optimal removal of Radon or other VOCs, other contaminants such as iron, or manganese must be removed before the water supply enters the AIRRaider™ System.

**Failure to remove other contaminants can reduce the effectiveness of the system
and may result in system damage.**

2. Installation Instructions

OVERVIEW

Now you are ready to begin the installation process. The eight steps to properly install the AIRraider™ System are listed below. Read all components of each step prior to beginning the actual installation.

1. System Location
2. Readyng the System for Installation
3. Plumbing Hook Up
4. Electrical Hook Up
5. Vent Line Installation
6. Remote Air Intake Installation
7. System Start Up
8. System Check



SAFETY TIP: Do Not undertake any step for which you are Not Qualified



Figure 1
Typical System

2.1. System Location

When selecting the location for the AIRRaider™ System, five factors should be among those considered:

1. System Plumbing Hook-up. Find a location that will minimize the amount of plumbing necessary, this is typically in proximity to the well tank.
2. Electrical Hook-up. Keep in mind the need for accessibility to a 20 Amp dedicated 120VAC power supply or 30 Amp dedicated 230VAC power supply.
3. Exhaust Line Venting. The location of the system must allow for outside venting of the system exhaust above the eave of the structure. The Manufacturer requires that the exhaust pipe pitch back toward the system (see Section 2.5).
4. Remote Air Intake. If the system must be installed in an area with questionable air quality (i.e. furnace room, garage, crawl space) then ducting from the air intake to a remote location having good air quality may be required.
5. System must be level. The system should not be located on a significant slope as this may impede system performance.

Place the system in the location acceptable to customer that maximizes the ease of installation. All Local and State codes as well as any applicable AARST, EPA and/or State Radon standards must be adhered to when locating the AIRRaider™ (i.e. away from electrical panel, furnace, exits, etc.).

2.2. Readyng the AIRRaider™ for Installation (see Figure 3 for diagram of installed system)

1. Attach bypass assembly (sold separately) to system outlet.

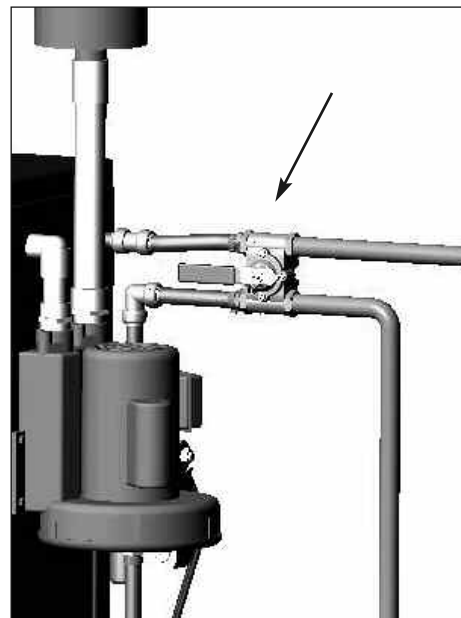

Figure 2
Bypass Assembly
(sold separately and may differ from image)

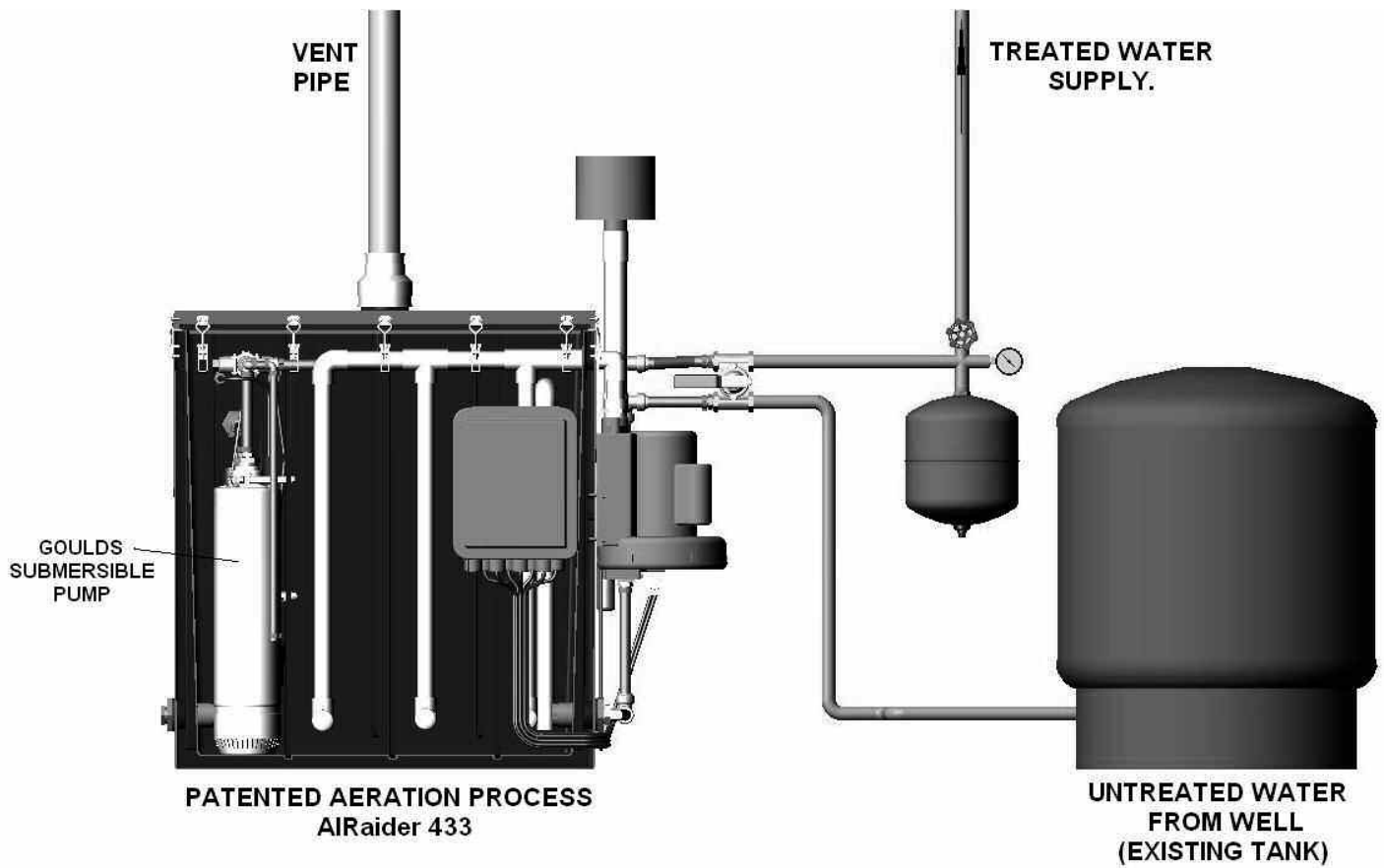

Figure 3
Diagram of Installed System
(bypass assembly and pressure tank sold separately)

2.3. Plumbing Hook-up (Figure 4)

All Plumbing should be performed in accordance with Local and State Codes by a Qualified and Licensed Plumber.

1. Shut off water main valve located after the pressure tank.
2. Drain water line.
3. Plumb system into water line after the pressure tank and all other water treatment equipment.
4. Plumb water line from the existing pressure tank into the inlet Shark Bite elbow via bypass valve (sold separately) labelled "Water In".
5. Plumb water line to house into the outlet Shark Bite labelled "Water Out" via the bypass valve.
6. Install pressure gauge on outlet piping.
7. Install 2.1 gallon pressure tank.
8. Connect 1" PVC overflow elbow on rear right hand side of the system to drain.
9. Making sure the Bypass is in the correct bypass configuration, slowly open the water main valve and check for leaks.
10. Slowly change bypass to the "service" configuration (in a position where water flows through the aeration system and then into the house). The submersible pump will self prime as the tank fills.

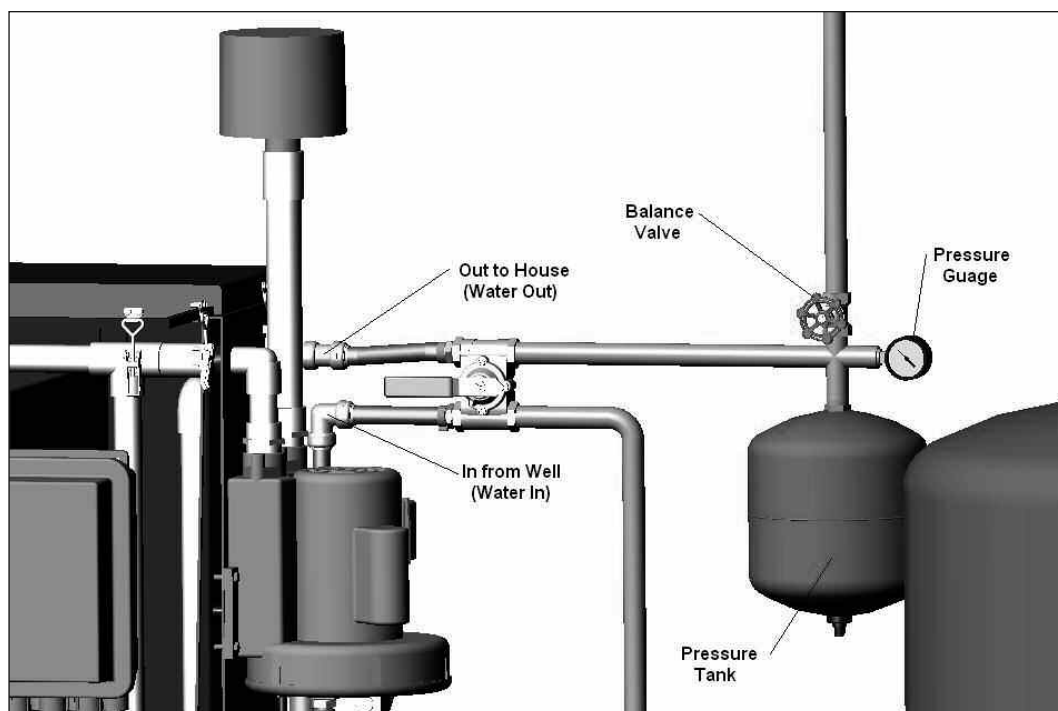

Figure 4
Water Connections

2.4. Electrical Hook-up

All Electrical Work should be performed in accordance with Local and State Codes, and NFPA National Electrical Code, Standard #70 by a Qualified and Licensed Electrician.



WARNING: Never perform electrical work while standing in water. Do not attempt wiring on a live circuit.

WARNING: Power Supply Voltage must match that marked on the System Name Plate. Improper wiring may result in system damage.

1. Turn main power switch, located on the AIRaider™, to the “Off” position.
2. Make sure all connections in the control panel are tight.
3. Bring in power to the control panel using the hole provided, either an appropriate strain relief bushing, or electrical conduit fitting(s), with correctly rated electrical wire or cable must be used in accordance with all applicable Electrical Codes.
4. Connect the power line to the control panel as shown in the appropriate wiring diagram (See Figures 5 & 6).
5. Connect power line to power source.* The required Voltage is either 120V or 240V and is indicated by an “X” marked in the check box next to either the 120V or 240V marking on the nameplate. Follow all code requirements regarding wire and circuit breaker size.

*** Manufacturer recommends that the AIRaider™ System be directly wired to the panel on a dedicated circuit.**

433-S75 with 3/4 hp Submersible Pump 230V-1Ph-60Hz Power Supply

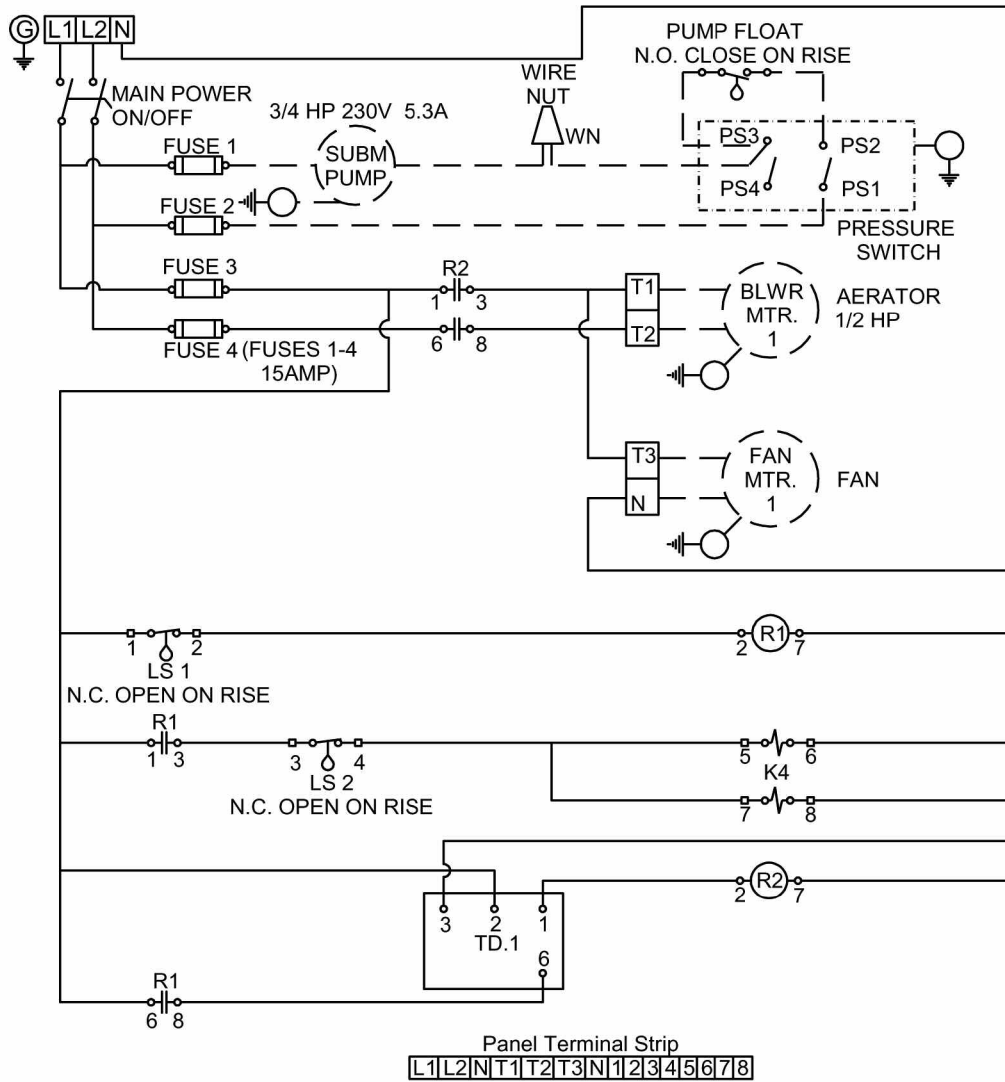

Component	Black	White	Red	Green
Power In (230V)	L1	N	L2	Ground
On/Off Float (middle)	1	2		
Fail Safe Float (upper)	3	4		
Solenoid	5	6		Ground
Solenoid	7	8		Ground
Blower	T1	T2		Ground
Pump	Fuse 1	WN		Ground
Vent Fan (if used)	T3	N		Ground
Pump Float (lower)	PS3	PS2		
Pressure Switch	WN-PS3	FUSE 2-PS1		Ground

Note:
 1. 230V Operation Requires a Power Connection Consisting of a Three Wire Cable with a Ground.

Figure 5
 AIRraider™ 433-S75 Wiring Diagram
 230V

433-S50 with 1/2 hp Submersible Pump 115V-1Ph-60Hz Power Supply

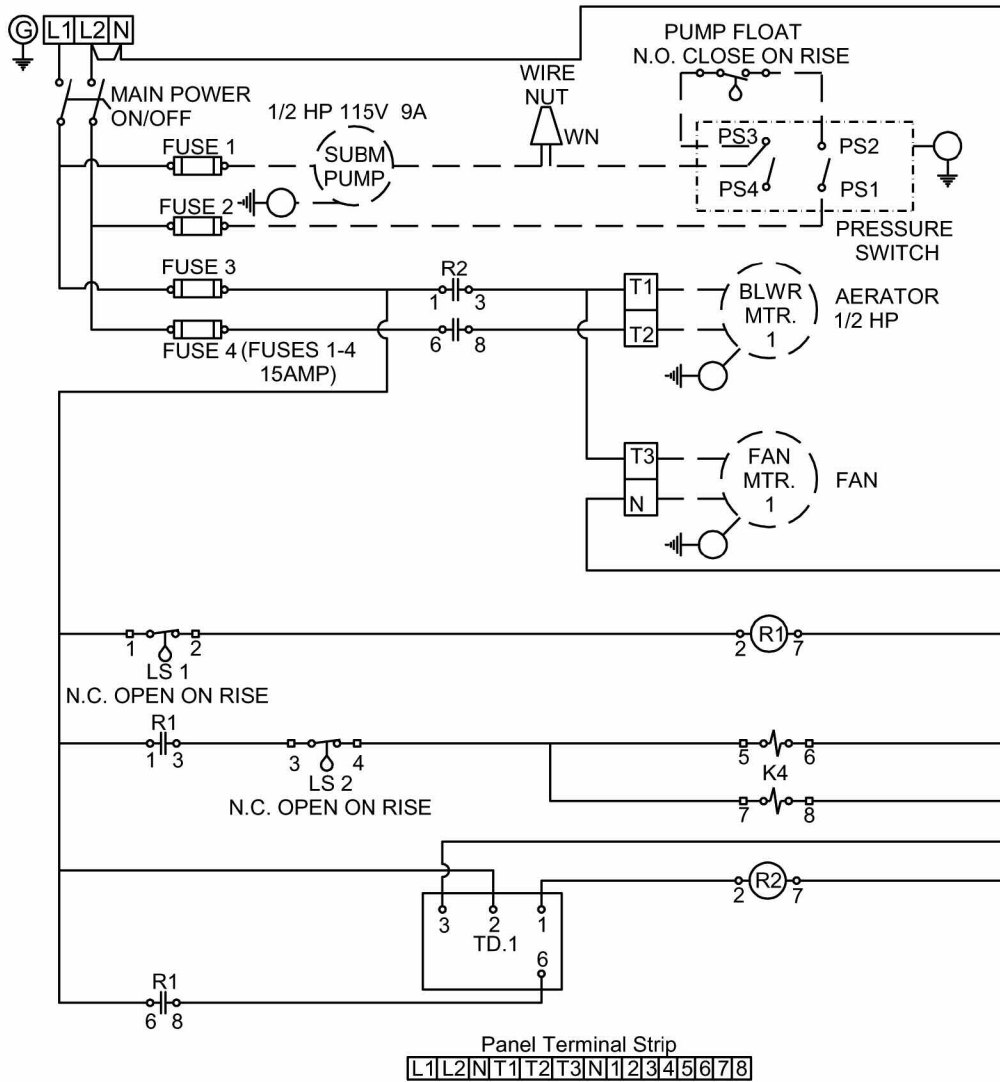

Component	Black	White	Red	Green
Power In (115V)	L1	N		Ground
On/Off Float (middle)	1	2		
Fail Safe Float (upper)	3	4		
Solenoid	5	6		Ground
Solenoid	7	8		Ground
Blower	T1	T2		Ground
Pump	Fuse 1	WN		Ground
Vent Fan (if used)	T3	N		Ground
Pump Float (lower)	PS3	PS2		
Pressure Switch	WN-PS3	FUSE 2-PS1		Ground

Figure 6
 AIRaider™ 433-S50 Wiring Diagram
 115V

2.5. Vent Line Installation

Use only 2", 3" or 4" Schedule 40 PVC or equivalent pipe for vent line. Follow all applicable AARST, EPA, and/or State Standards for Radon or VOC venting.

1. Place the lid of the AIRRaider™ on to the tank lining up the clips with the clasps on the tank. Adjust clasps so that when anchored to the clips the lid sits snugly on the tank gasket.
2. Connect vent line to AIRRaider™ lid using the enclosed rubber coupling (See Figure 7).
3. The vent line must be routed in a fashion that allows the system to exhaust above the level of the roof (See Figure 8).
NOTE: When "Freeze Up" is possible, a minimum pipe diameter of 3" is recommended (See Figure 9).
4. The vent line must be pitched back toward the system to prevent condensation build up.
5. Cement all fittings to ensure no leakage will occur. Be certain to use cement that is suitable for potable water applications.
6. Install weather cap on top of the vent line. This cap should not restrict air flow and must prevent rain, snow and other contaminants from entering the vent line.



Figure 7
Vent Line Connection



Figure 8
Vent Line Installation (2 inch)



Failure to install a proper vent line may cause contamination of the water, outgassing of contaminants into the building, and/or limit system performance.

** The Manufacturer has found that vent lines less than 250 equivalent linear feet do not cause a decrease in contaminant removal percentages. 90° Bend = 15 Equiv. Linear Ft ; 45° Bend = 7 Equiv. Linear Ft.*



Figure 9
Vent Line Installation (3 inch)

2.6 Install Air Filter (Figure 10)

1. Install air filter provided using the PVC pipe and fittings provided.

2.6.1 Remote Air Intake (Figure 11)

If a Remote Air Intake is required because of air quality or quantity issues then use only 1-1/4" or larger Schedule 40 PVC or equivalent pipe for the air intake line.

1. Connect air intake line to the blower using the proper reducer coupling.
2. Run the intake line from the pipe connection on the blower to the location selected for air intake.
Note: Manufacturer recommends a flexible coupling or similar means to disconnect the intake line from the blower.

3. Connect the Air Filter to the intake vent line using the proper reducer coupling.

Note: Any outside Air Intake must be mounted high enough off the ground to prevent the drawing in of snow, water and other contaminants. Do not locate the Air Intake in the vicinity of vents from furnaces, barbecue grills, etc.

NOTE: In-Line Air Filters are available from the Manufacturer.

2.7. System Start-Up

1. Remove cover and lid and pour ¼ cup of chlorine into the first chamber. (This will disinfect the system.) Replace the lid making sure all clasps are engaged properly.
2. Check that all plumbing and electrical connections have been properly completed.
3. Slowly change bypass to the "service" configuration (in a position where water flows through the aeration system and then into the house). Check for leaks.
4. Turn power switch for AIRraider™ to "On". Solenoid Valves will now open allowing water into the system. The aeration process will also start. Check for leaks.
5. Allow the AIRraider™ to fill with water.
6. The submersible pump will prime as the tank fills.

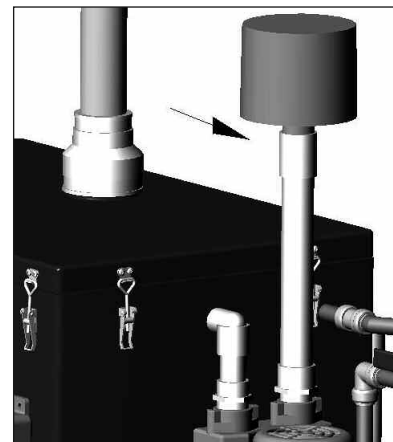

Figure 10
Air Intake Connection



Figure 11
Air Filter



Figure 12
Installed AIRraider™ 433-S

2.8 System Check

1. Run the system through a couple of cycles to ensure all components are working properly.
2. The blower timer is preset for 5 minutes delay. After the solenoid valves shut, check that the blower continues running for the preset number of minutes delay.
3. Open the tank and check the system.
 - a. Remove the tank lid.
 - b. Lower the water level in the tank by opening a bath tub tap, or similar, within the residence. The bottom float will fall with the water level. When minimum water level is reached, there will be an audible click and the solenoids will open, allowing the tank to start filling; the blower should also start running. The water level must rise regardless of how many taps are open within the residence.
 - c. While the tank is filling, lift the lower float. Water in flow should stop and the blower will remain running (until the end of the preset delay).
 - d. Release the lower float. While the tank is still filling, lift the upper float. Water in flow should stop and the blower will remain running.
 - e. Release the upper float.
 - f. Remember to shut off any open taps within the residence.
4. Replace the lid and secure all clasps. With the System running check the lid for air leaks between lid gasket and tank. If leaks occur the clasps should be adjusted until leaks are eliminated.
5. Make sure you have properly labeled the system with the necessary installer information (i.e. company name, phone number, date installed, etc). Leave all system information with the home owner.
6. The AIRaider™ System is now operational.

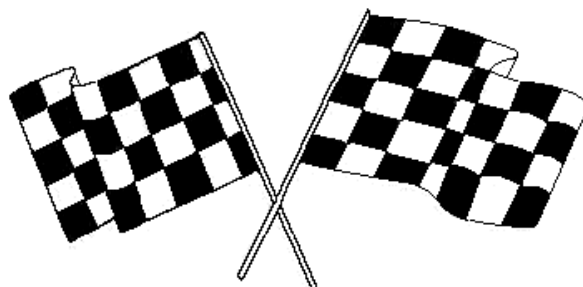

3. Retesting

After the AIRaider™ Installation, the installer should perform another water analysis to ensure proper system performance. This sample should be performed one week after the date of installation.

Sampling Procedure:

1. Remove aerator from faucet or spigot, if applicable.
2. Run water so that the AIRaider™ operates for two cycles.
3. Turn off water for 5 minutes.
4. Turn water on and proceed with sampling as per the laboratory instructions.

4. Maintenance

Proper maintenance of the AIRaider™ can prevent possible system failure and provide years of trouble-free service.

4.1. Six-Month Service (recommended)

The following procedures should be followed to maintain the AIRaider™ :

- Check and/or clean the blower air intake filter.
- Check and/or clean any filters or strainer installed on the inlet line to the AIRaider™. In installations with particularly high levels of sediment cleaning of filters may be required more frequently.
- Check and clean inlet screen on pump.
- Using a wet/dry vac, clean sediment from bottom of aeration tank if necessary.
- Clean (if necessary) tank and diffusers of all mineral build up.
- Chlorinate tank and lines by pouring ¼ cup of chlorine into the first aeration chamber.
- Check all control panel connections and electrical components (blower, pump, timer, fuses, etc.) for proper operation.
- Check float switches for proper operation.
- Inspect vent line for possible obstructions.
- Run system through two cycles to ensure good working order.

4.2. Annual Service (required)

The following procedures should be followed annually to maintain the AIRaider™:

- Clean solenoids and switch coil locations.
- Check all hose connections.
- Check and/or clean the blower air intake filter.
- Check and/or clean any filters or strainer installed on the inlet line to the AIRaider™.
- Check and clean inlet screen on pump.
- Using a wet/dry vac, clean sediment from bottom of aeration tank if necessary.
- Clean (if necessary) tank and diffusers of all mineral build up.
- Chlorinate tank and lines by pouring ¼ cup of chlorine into the first aeration chamber.
- Check all control panel connections and electrical components (blower, pump, timer, fuses, etc.) for proper operation.
- Check float switches for proper operation.
- Inspect vent line for possible obstructions.
- Run system through two cycles to ensure good working order.
- Perform Water Test.

* Every 3 years during the annual service replace all hoses.

** Every 5 years during the annual service replace the solenoid valves.

5. Troubleshooting

Symptom

Solution

No water in house	<ul style="list-style-type: none"> · Check power: switch in on position; circuit breaker at panel in on position; fuses in control panel intact. · Check pressure in tank. If below the proper settings, reset the pump as described in system start-up. · Bypass System. If there is still no water, main well pump may not be functioning. · Check on/off float for proper operation. Replace if necessary.
System running dry	<ul style="list-style-type: none"> · Check sediment strainer and/or filter (if applicable) and clean if necessary. · Install a flow restrictor or meter down the ball valve until the AIRaider™ outflow is 1 GPM or more less than the water flow entering the system.
Water not entering system	<ul style="list-style-type: none"> · Check solenoids for proper operation. Replace if necessary. · Check float switches float for proper operation. Replace if necessary. · Check sediment strainer and/or filter (if applicable) and clean if necessary.
Submersible Pump not Functioning	<ul style="list-style-type: none"> · Check fuse in control panel. · Check breaker at electrical panel. · Replace submersible pump if necessary. · Check pressure switch setting.
Pressure in tank is less than 40 PSI	<ul style="list-style-type: none"> · Check pressure switch. · Check bladder tank. · Check submersible pump. · Check smart valve. · Replace any of these parts as necessary.
Low water flow at faucets	<ul style="list-style-type: none"> · Clear sediment strainers on faucets. · Clear pump inlet screen/water injector. · Replace pump if necessary.
Loud banging when solenoids shut	<ul style="list-style-type: none"> · Install loop of flexible hose in system inlet line. · Shorten the length of pipe between the well pressure tank and the system.
Solenoids chatter when closing	<ul style="list-style-type: none"> · Check On/Off float for proper operation. Replace if necessary.
Blower not running	<ul style="list-style-type: none"> · Check fuses in control panel. · Replace timer if necessary. · Replace blower if necessary.
Blower does not stop running	<ul style="list-style-type: none"> · Check On/Off float for proper operation. · Check timer Settings. · Replace timer relay if necessary.
Pump is short cycling	<ul style="list-style-type: none"> · Bladder tank may be ruptured. Replace if necessary. · Check pressure switch on for proper operation. · Check Smart Valve for proper operation.

Limited Warranty

Subject to applicable consumer protection legislation, Spruce Environmental Technologies, Inc. (Spruce) warrants that the AIRaider™ will be free from defective materials and workmanship for the period of two (2) years from the date of purchase.

Warranty is contingent on installation in accordance with the instructions provided. This warranty does not apply where repairs or alterations have been made or attempted by others; or the unit has been abused or misused. Warranty does not include damage in shipment unless the damage is due to the negligence of Spruce. To make a claim under these limited warranties, you must return the defective item to Spruce. All other warranties, expressed or written are not valid. Spruce is not responsible for installation or removal cost associated with this warranty. In no case is Spruce liable beyond repair or replacement of the defective product FOB Spruce.

SPRUCE SPECIFICALLY DISCLAIMS ANY WARRANTY OF FITNESS FOR A PARTICULAR PURPOSE.

THERE ARE NO WARRANTIES WHICH EXTEND BEYOND THE DESCRIPTION ON THE FACE HEREOF. THERE IS NO WARRANTY OF MERCHANTABILITY. ALL OTHER WARRANTIES, EXPRESSED OR WRITTEN, ARE NOT VALID.

In order to obtain service under this warranty, the consumer must contact the installer or dealer where the unit was purchased. The installer or dealer must then contact Spruce directly for a Return Merchandise Authorization (RMA) number and shipping information. **No returns can be accepted without an RMA.** Spruce may require the defective part(s) to be returned to place of manufacture (freight pre-paid) to process the warranty claim. Defective part(s) covered under this warranty will be replaced or repaired at the place of manufacture and returned to the installer or dealer (freight pre-paid). In replacing or repairing parts or products, Spruce reserves the right to make such changes in the details of design construction, arrangement or make materials as shall in its judgment constitute an improvement over former practice.

Record the following for your records:

Serial No. _____ Date Purchased: _____



3 Saber Way
P.O. Box 8244
Ward Hill, MA 01835
Phone: (800) 355-0901
Fax: (978) 521-3964
E-mail: sales@spruce.com



3 Saber Way
P.O. Box 8244
Ward Hill, MA 01835
Phone: (800) 355-0901
Fax: (978) 521-3964
E-mail: sales@spruce.com